



**GC80/85**  
**Double System Controller**  
**User Manual**

ENGLISH



## Document history

Rev. 001	First review
----------	--------------

# 1 PREFACE

## 1.1 Compliance statement

Navico declare under our sole responsibility that the GC80/85 conform with the requirements of:

- The European Council Directive 2014/90/EU on Marine Equipment modified by Commission Implementing Regulation (EU) 2019/1397 - Wheelmark.

All compliance documents are available in the product's section at the following website: [www.navico.com/commercial](http://www.navico.com/commercial).

## 1.2 Disclaimer

As Navico is continuously improving this product, we retain the right to make changes to the product at any time which may not be reflected in this version of the manual.

Please contact your nearest distributor if you require any further assistance.

It is the owner's sole responsibility to install and use the equipment in a manner that will not cause accidents, personal injury or property damage. The user of this product is solely responsible for observing maritime safety practices.

NAVICO HOLDING AS AND ITS SUBSIDIARIES, BRANCHES AND AFFILIATES DISCLAIM ALL LIABILITY FOR ANY USE OF THIS PRODUCT IN A WAY THAT MAY CAUSE ACCIDENTS, DAMAGE OR THAT MAY VIOLATE THE LAW.

This manual represents the product as at the time of printing. Navico Holding AS and its subsidiaries, branches and affiliates reserve the right to make changes to specifications without notice.

### **Governing language**

This statement, any instruction manuals, user guides and other information relating to the product (Documentation) may be translated to, or has been translated from, another language (Translation). In the event of any conflict between any Translation of the Documentation, the English language version of the Documentation will be the official version of the Documentation.

## 1.3 Copyright

Copyright © 2021 Navico Holding AS.

## 1.4 Trademarks

Navico® is a registered trademark of Navico Holding AS.

Simrad® is used by license from Kongsberg.

## 1.5 About this manual

### Intended audience

This manual is intended as a reference guide for installing, operating and maintaining the GC80/85 Double System Controller unit.

The manual assumes that the operator is a qualified ship officer, or is under supervision of a qualified person.

### Important text conventions

In this manual, references to buttons on the operator panels are written in boldface, but in a different text style (e.g. **MENU** button, **SET/ENT** button, **HDG** button).

Important text that requires special attention from the reader is emphasized as follows:

Note!

*Used to draw the reader's attention to a comment or some important information.*

Caution

*Used to warn the reader that a risk of damage to the equipment exists if care is not exercised.*

**WARNING**

**Used when it is necessary to warn personnel that a risk of injury or death exists if care is not exercised.**

This manual is divided into the following sections:

**1. Preface**

**2. System overview**

*An overview of the GC80/85 Double System Controller unit and its components.*

**3. User interface**

*An overview of GC80/85 Double System Controller unit and the user interface.*

**4. Operation**

*Main operating procedures for using the GC80/85 Double System Controller unit.*

**5. Maintenance**

*Simple maintenance procedures that should be performed by the system operator.*

**6. Installation**

*Mechanical installation, cable connection, and software configuration for the GC80/85 Double System Controller unit.*

**7. Technical specifications**

*Specifications for the system and for all separate units in the GC80/85 Double System Controller unit.*

**8. Drawings**

*Dimensional drawings and wiring diagrams for the GC80/85 Double System Controller unit.*

**9. Part list**

*List of all standard and optional units that are used in the GC80 and GC85 Double System Controller unit.*

**10. Terminal layout**

*List of all terminal pins and terminal labelling with details on GTERM-A board in the GC80/85 Double System Controller unit.*

**11. DIP switch settings**

*Drawings and references of jumpers and DIP switches for the different printed circuits boards in the Double System Controller unit.*

**12. Alarm messages and corrective actions**

*A description of how system errors are indicated and corrective actions that can be performed by the operator.*

**13. Troubleshooting**

## Contents

<b>1</b>	<b>PREFACE .....</b>	<b>4</b>
1.1	Compliance statement.....	4
1.2	Disclaimer .....	4
	Governing language.....	4
1.3	Copyright .....	4
1.4	Trademarks .....	4
1.5	About this manual .....	5
	Intended audience.....	5
	Important text conventions.....	5
<b>2</b>	<b>SYSTEM OVERVIEW .....</b>	<b>11</b>
2.1	Introduction.....	11
2.2	Precautions in use .....	12
2.3	System components.....	12
2.4	Bearing repeaters .....	14
<b>3</b>	<b>USER INTERFACE .....</b>	<b>15</b>
3.1	General.....	15
3.2	Control panel .....	15
	Heading sensor indicators.....	15
<b>4</b>	<b>OPERATION .....</b>	<b>17</b>
4.1	System start-up and shut-down.....	17
	Power ON/OFF .....	17
4.2	Display .....	18
	Start screen .....	18
	Display menu list .....	18
	Main screen.....	19
	Screen when the gyrocompass is settling.....	19
	Screen when an Alert occurs.....	20
4.3	Select heading sensor .....	20
	Sensor selection.....	20
4.4	Adjust display illumination and display test .....	20
	Adjust display brightness.....	20
	Display test .....	21
4.5	Alarm messages .....	21

	Central alarm panel .....	21
	BAMS .....	21
<b>5</b>	<b>MAINTENANCE.....</b>	<b>22</b>
5.1	General.....	22
5.2	Precautions.....	22
5.3	Cleaning the operator panels and the cabinet surface .....	23
5.4	Check warning label.....	23
5.5	Checking the connectors.....	23
5.6	Checking mechanical installation.....	23
5.7	Preventive maintenance intervals.....	23
5.8	Replacing the fuses.....	24
	GC80/85 Double System Controller unit .....	24
5.9	Storage and disposal methods.....	26
5.10	Heading sensor parameter check .....	26
<b>6</b>	<b>INSTALLATION .....</b>	<b>28</b>
6.1	Unpacking and handling .....	28
6.2	Mechanical installation .....	28
	Control unit .....	28
6.3	Cabling .....	29
	Power supply.....	30
6.4	Grounding the unit.....	30
6.5	DIP switch and jumper settings .....	30
	Activating the GC80 or GC85 Double System Controller unit.....	30
6.6	Activating or deactivating the automatic switch.....	32
6.7	Expanded Control unit settings in a Double gyro system.....	32
6.8	Parameter settings .....	33
<b>7</b>	<b>TECHNICAL SPECIFICATIONS .....</b>	<b>34</b>
7.1	General specifications .....	34
7.2	Input specifications.....	35
7.3	Output specifications.....	37
7.4	Physical dimensions .....	38
	GC80/85 Double System Controller unit .....	38
7.5	Power .....	38
	GC80/85 Double System Controller unit .....	38

7.6	Environmental specifications .....	39
	GC80/85 Double System Controller unit .....	39
<b>8</b>	<b>DRAWINGS .....</b>	<b>40</b>
8.1	Drawings included .....	40
<b>9</b>	<b>PART LIST.....</b>	<b>47</b>
9.1	GC80/85 Double System Controller unit.....	47
9.2	GC80/85 optional equipment, Double System Controller unit ..	47
<b>10</b>	<b>TERMINAL LAYOUT .....</b>	<b>48</b>
10.1	DGCT board.....	48
	TB1 .....	48
	TB2 .....	48
	TB3 .....	49
	TB21 .....	50
	TB22 .....	50
	TB23 .....	51
	TB24 .....	52
	TB25 .....	53
	TB26 .....	53
	TB27 .....	54
	TB28 .....	54
	TB29 .....	55
	TB30 .....	55
<b>11</b>	<b>DIP SWITCH SETTINGS.....</b>	<b>56</b>
11.1	Double System Controller unit .....	56
	DGCIF board .....	57
	SCC boards .....	62
	DGCT board.....	66
<b>12</b>	<b>ALERT MESSAGES AND CORRECTIVE ACTIONS .....</b>	<b>67</b>
12.1	The alert system .....	67
	Alert display .....	67
	Display when an alert occurs.....	67
	Alert list.....	68
	Alert history .....	68
12.2	Acknowledging an alert .....	69
	Operation when an alert is activated .....	69

Contents

Check alert screen.....	71
Check alert list and alert history .....	71
12.3 Complete alarm code lists .....	72
Alerts detected on Double.....	72
Alert detected in GC80/85 Expanded No.1 .....	74
Alert detected in GC80/85 Expanded No.2 .....	74
Alarm priority list .....	75
<b>13 TROUBLESHOOTING .....</b>	<b>77</b>

## 2 SYSTEM OVERVIEW

This section provides an overview of the GC80/85 Double System Controller unit and its components.

### 2.1 Introduction

The GC80/85 Double System Controller unit has been designed for any size of vessels to enhance the navigational capabilities and reliability. The system controller outputs the true heading of the selected gyrocompass and an optional heading sensor.

This system is developed based on the international standards, which are as follows:

- **ISO 8728**  
Ships and marine technology – Marine gyrocompasses.
- **IEC Standard 60945 Ed.4**  
Maritime navigation and radio communication equipment and systems - General requirements - Methods of testing and required test results.
- **IEC Standard 61162-1 Ed.4**  
Maritime navigation and radio communication equipment and systems, digital interface.
- **IEC Standard 61162-2 Ed.1**  
Maritime navigation and radio communication equipment and systems, digital Interface.  
Single talker and multiple listeners, high speed transmission.
- **IEC 62288 Ed.1**  
Presentation of navigation-related information on shipborne navigational displays – General requirements – Methods of testing.

The new Double System Controller unit is developed to meet the requirements of the NAUT-OC/NAUT-AW with the new Dual gyrocompass system.

These requirements are:

- 1 Two-way communication feature between the Dual gyrocompass system and BAMS (Bridge alarm management system) for alarm transfer and alarm acknowledgement.
- 2 No interruption in heading information when having any trouble in either of the two gyrocompass systems. Note that the current gyrocompass system has common interface hardware for signal input/output.
- 3 Backup requirement for speed error correction and abnormal conditions with 2 inputs of GNSS (position) and SDME (speed).
- 4 No jumping when changing heading information among 2 or more heading sensors.

- 5 Heading information between sensors should be selected by external serial command.
- 6 Physical separation in the system should be achieved in all respects as specified.
- 7 Character size and other display features and indications should meet the requirement of IEC22288.
- 8 Dual serial output circuits should be installed.
- 9 Gyrocompass should cover the performance requirement based on the IMO performance standard up to latitude 75 deg.

The GC80/85 Double System Controller unit covers international performance requirements (IEC61924) and notations specified by other classification bodies.

## 2.2 Precautions in use

The GC80/85 Double System Controller unit displays and outputs bearing information. Although the system continually checks for faults while the system is running, failures or malfunctions may occur.

Any errors in input information will generate an alarm. These errors may also cause large jumps in the output bearing from the gyrocompass. If this happens, any external equipment depending on the bearing output from GC80/85 Double System Controller unit should be operated manually or switched to other bearing sensors.

To assure long time safe operation, the following precautions should be taken:

- Assure that the operator is familiar with the use of the gyrocompass.
- Read the safety precautions in this manual.
- Perform daily checks to maintain normal system operation. Refer to "MAINTENANCE", page 22 onwards.
- Before taking any measures, check the navigational condition around the vessel for safety and stop at non-dangerous sea areas.
- If any unusual behavior is observed during daily inspections, the cause should be found and corrected. If necessary, the local Simrad dealer should be contacted. Refer to [www.navico-commercial.com](http://www.navico-commercial.com) for a list of Certified Dealers and Distributors.
- If any alarm is generated, verify the reason for the alarm. Take appropriate measures by following the directions in the alert list.

## 2.3 System components

The new Double system has been developed on the concept of 2 sets of standard single gyrocompass systems having serial heading outputs with the new system controller unit.

A GC80/85 Double System Controller unit includes the following units:

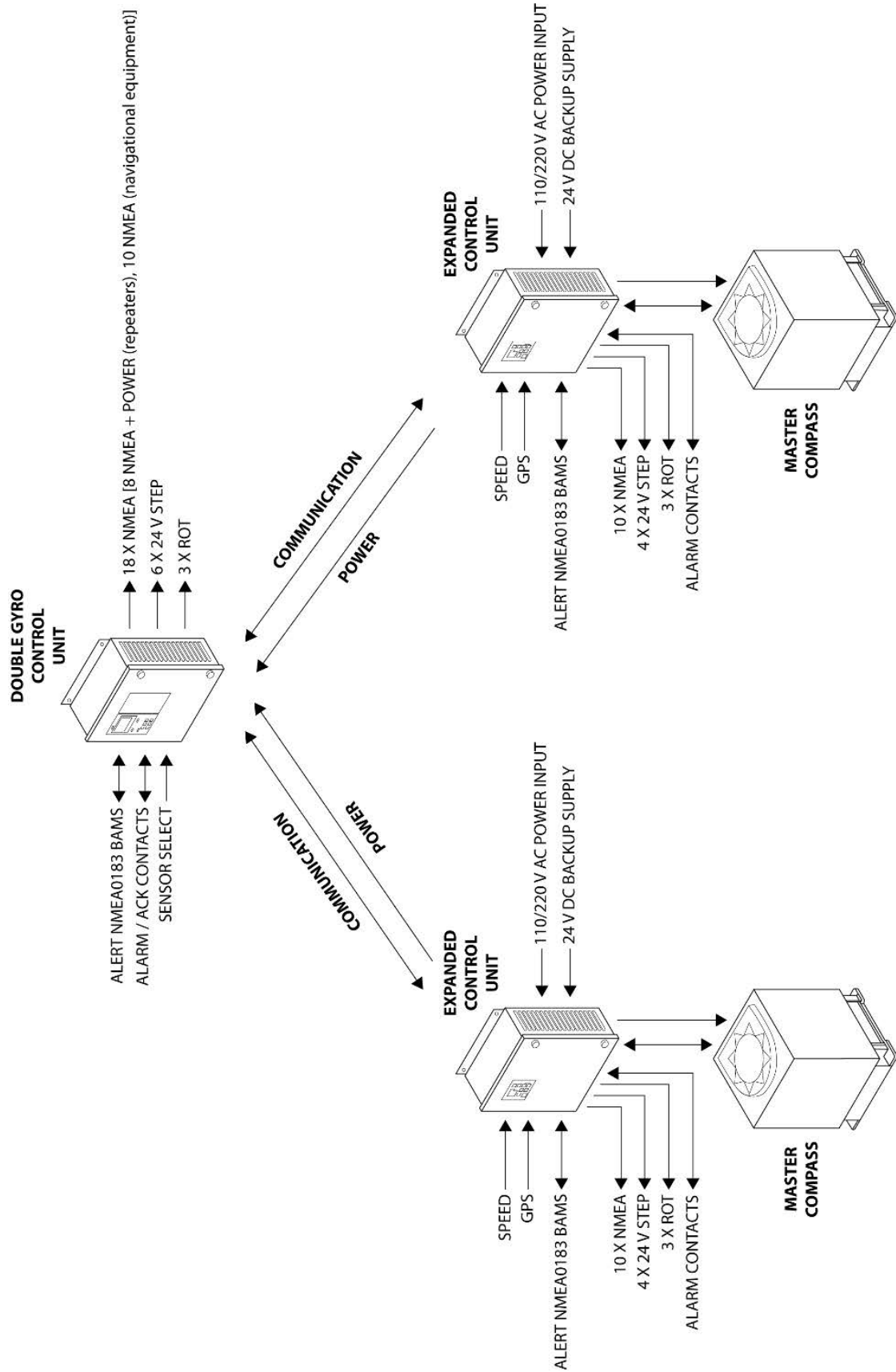

Note!

For details, refer to "TECHNICAL SPECIFICATIONS" on page 34.

## 2.4 Bearing repeaters

The Double controller unit outputs step and serial signals used for repeaters. Even when the emergency power supply is used, the connected repeaters will be powered by the repeater backup function included in the Double controller unit.

The following serial signals may be selected:

Low speed (GC80): IEC61162-1 ed.4 (4800 and 38400 baud possible)

High speed (GC85): IEC61162-2 ed.1 (38400 baud possible)

Note!

*A proprietary Tokimec serial signal may also be available, but this is normally not used.*

These signals may be set separately for each circuit.  
For connection of repeaters, refer to the wiring diagrams from page 40 onwards.

### 3 USER INTERFACE

This section gives an overview of the GC80/85 Double System Controller unit and the user interface.

#### 3.1 General

The Double System Controller unit includes 1 control panel.

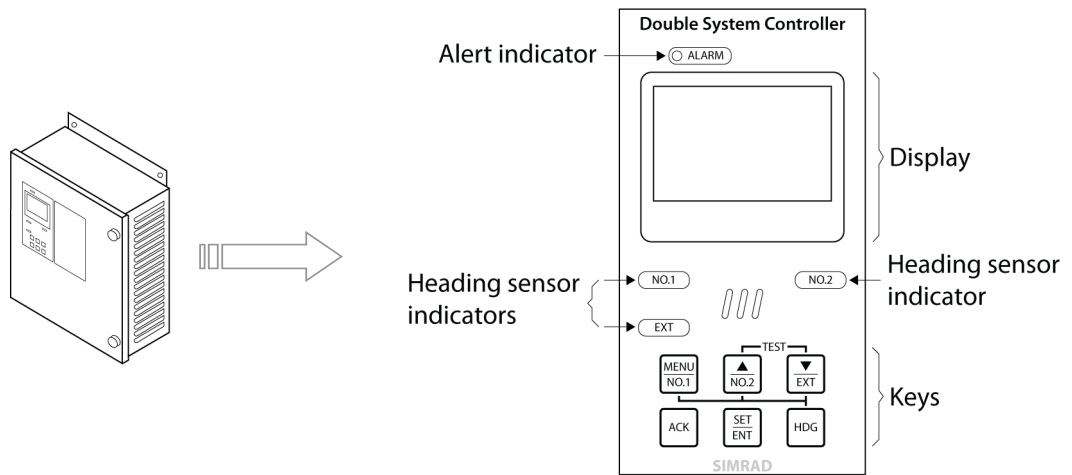

#### 3.2 Control panel

The control panel includes the buttons described on the following pages.

##### Heading sensor indicators

NO.1

##### NO.1 indicator

Indicates the status of the NO.1 gyrocompass:

- Green LED: Normal operation
- Red LED: Error
- OFF: Not installed

Refer to "Select heading sensor" on page 20.

NO.2

##### NO.2 indicator

Indicates the status of the NO.2 gyrocompass:

- Green LED: Normal operation
- Red LED: Error
- OFF: Not installed

Refer to "Select heading sensor" on page 20.



**EXT indicator**

Not used.



**▽/EXT key**

Used to adjust the illumination and move the cursor down.



**MENU/NO.1 key**

Select to open the display menu list. Refer to “Display menu list” on page 18.

This key is also used to select the NO.1 gyrocompass as the primary heading sensor. Press the **MENU/NO.1** key and the **HDG** key simultaneously.

Used to change data and input sources.



**△/NO.2 key**

Used to adjust the illumination and to move the cursor up.

This key is also used to select the NO.2 gyrocompass as the active heading reference source.

Refer to “Select heading sensor” on page 20.



**ACK key**

Used to acknowledge alerts (buzzer stop).



**SET/ENT key**

Select to change the value. Select again to confirm the operation and value.



**HDG key**

Used to change the primary heading sensor. Press simultaneously the **HDG** key and the desired heading sensor button to change the primary heading sensor.



Used to increase or decrease a parameter value.

Press both keys for lamp test and to set the display illumination as described on page 21.



**Alarm indicator**

Used to indicate an alarm situation. Refer to “Alarm messages” on page 21.

## 4 OPERATION

This section describes the main operating procedures used when operating the GC80/85 Double System Controller unit.

### WARNING

**Malfunctions by system failure or improper actions by the system operator may cause sea accidents.**

Pay close attention to the system by understanding its limitations in performance and characteristics.

Do not apply strong shocks to the display panel. The display is protected with acrylic cover, but the inner display uses a thin glass panel.

### 4.1 System start-up and shut-down

A GC80/85 Double System Controller unit is usually left with power ON. If the system has to be shut down and restarted, follow the procedures described in the following sections.

#### Power ON/OFF

##### Power ON

- 1 The two CG50/85 Expanded systems must be turned On or turned On as described in the CG80/85 Expanded MK2 User manual. Then, the two internal switches in the Double controller unit, SW101 and SW102. SW101 will turn On power and signals from Gyro system NO.1 and SW102 will turn On power and signals from Gyro system NO.2.
- 2 The start screen is displayed for 3 seconds.

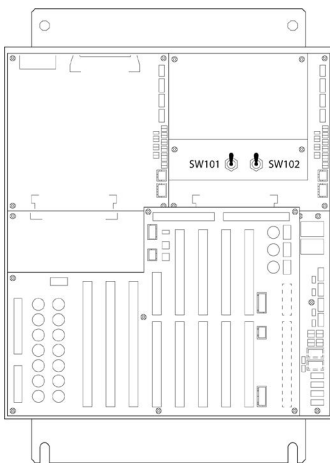

- 3 The true heading screen is displayed.



### Power OFF

When powering Off the system the internal switches SW101 (Gyro No.1) and SW102 (Gyro No.2) can be turned to OFF. Power and signals from the gyros will then be turned Off.

If gyros are to be stopped completely you must follow the stop procedure explained in the GC80/85 Expanded MK2 User Manual.

## 4.2 Display

### Start screen

Turn on NO.1 gyrocompass, NO.2 gyrocompass to start the unit. The start-up screen is displayed for 3 seconds.

The unit name, model name, and software version are displayed on the screen.

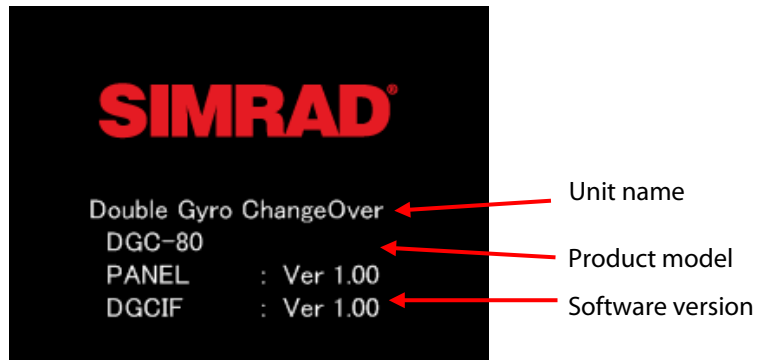

### Display menu list



- 1 Press **MENU/NO.1** to open the display menu list in the upper left corner of the screen.  
Re-press **MENU/NO.1** to close the menu.



### Main screen

- 1 Select <MAIN> in the display menu list.
- 2 A list of the connected heading sensor(s) is displayed. The true heading of the selected heading sensor is displayed [SELECTED].



When NO.1 gyrocompass is selected.

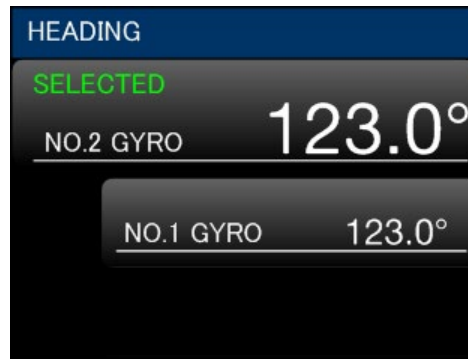

When NO.2 gyrocompass is selected.

### Screen when the gyrocompass is settling

- 1 Select <MAIN> in the display menu list.
- 2 When the gyrocompass is settling, [STANDBY] is displayed.



### Screen when an Alert occurs



Display when an alert occurs. Refer to "ALERT MESSAGES AND CORRECTIVE ACTIONS" on page 67.

## 4.3 Select heading sensor

### Sensor selection

- 1 The unit outputs the true heading of the selected gyrocompass.
  - To select NO.1 gyrocompass, press the  $\Delta$ /NO.1 key and the HDG key simultaneously.
  - To select NO.2 gyrocompass, press the  $\Delta$ /NO.2 key and the HDG key simultaneously.

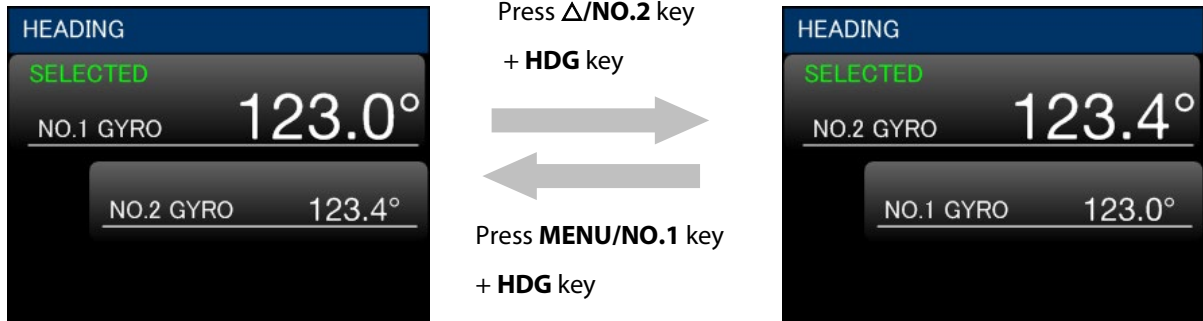

## 4.4 Adjust display illumination and display test

### Adjust display brightness

On the main screen:

Press  $\Delta$ /NO.2: Up.

Press  $\nabla$ /EXT: Down.

## Display test

Press and hold the  $\Delta$ /NO.2 key and the  $\nabla$ /EXT key simultaneously. Check the display, the key backlight, and the buzzer sound.

The system operates normally if:

- 1 Display: Shows the image below.



Display during test

- 2 Lighting of the display and the keys:
  - Lights up at maximum brightness.
- 3 Buzzer: continuous sound.

## 4.5 Alarm messages

### Central alarm panel

On some installations, it is required to connect the gyro to an external bridge alarm panel. In these types of installations, the functions mentioned above and the alarm contact output are used to fulfil this requirement.

### BAMS

It is possible to connect to a BAM system via serial connection. Refer to "TECHNICAL SPECIFICATIONS" on page 34, and "DRAWINGS" on page 40.

## 5 MAINTENANCE

This section describes maintenance procedures that should be performed by the system operator.

### 5.1 General

**Caution**

*All units in the GC80 Double System Controller unit are designed for optimum safety and reliability. However, a limited amount of preventive maintenance should be performed to verify safe operation and durability.*

**Note!**

*If any strange motion, smell, sound, or heat is generated from any unit, please contact a Simrad dealer.*

The system consists of carefully selected parts based on safety design. However, periodic checks (operation checks) and maintenance described in the following sections must be performed to ensure long-term satisfactory operation.

The main purpose is to catch signs of system failure at an early stage. Assign a person in charge of the system and perform checks and maintenance under his responsibility.

### 5.2 Precautions

Do not tap or hit the display with metal, hard or sharp-edged materials.

Touching internal parts may cause electric shock if power is connected to the system, even if the **POWER** button is turned OFF. Do not touch any terminal board or power supply unit while maintaining and checking the system. If necessary, disconnect the power cable from the control unit.

Electrostatic charges may damage components on the circuit boards inside the units. Always wear a correctly connected earthing strap when opening the units.

The following warning label is attached to the dangerous position of the system:

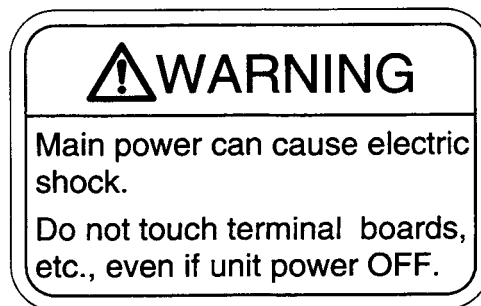

Main units of the system, which consists of electronic circuits, have high reliability. However, it could have any failure or error when in some unexpected conditions.

Do not use a megger etc., for insulation test of the system. Using a megger can break internal electric parts.

Always disconnect wirings connected to the system before testing related power distribution lines with a megger.

### 5.3 Cleaning the operator panels and the cabinet surface

The surface of the display is likely to keep foreign materials due to electrification.

Use a vacuum cleaner with a soft brush to avoid damaging the buttons and the panel. If required, clean the buttons and panel with a non-abrasive cloth moistened with mild soap solution.

### 5.4 Check warning label

Check and clean warning labels to read legibly.

### 5.5 Checking the connectors

The connectors should be checked by visual inspection only. Push the connector plugs into the connector. If the connector plugs are equipped with a lock, ensure that this is in the correct position.

### 5.6 Checking mechanical installation

Vibration and shock may cause mechanical parts to loosen. All fastening screws should therefore be checked regularly and eventually tightened.

### 5.7 Preventive maintenance intervals

Local evaluations should be made to determine site-specific maintenance intervals.

ACTION	INTERVAL RECOMMENDED
Confirm that the value of each repeater synchronizes with the displayed true bearing on the operating panel.	Daily
Confirm that the displayed latitude and speed are according to the vessel's actual latitude and speed. Refer to "Heading sensor parameter check" on page 23.	Daily
Confirm that the vessel's power supply voltage is stable within specifications.	Daily
Check connectors.	Every 6 months

Tighten fastening screws.	Every 6 months
Clean panels, labels, and cabinet.	Once a year or as required

Note!

*Refer to the Expanded Control Unit User Manual for the detailed maintenance procedure of the gyro compass sensitive element.*

## 5.8 Replacing the fuses

### WARNING

**Before a fuse is replaced, disconnect the respective power for the damaged fuse.**

Use the procedures described on the following pages when replacing the fuses.

### GC80/85 Double System Controller unit

For location of the fuses, refer to the drawing on the next page.

#### DGCT board

FUSE NO	CAPACITY	TB-NO	SIGNAL	DESCRIPTION
XF1	1 A	TB22 11	21_24V	Power supply for ch.21 serial repeater
XF2		TB22 16	22_24V	Power supply for ch.22 serial repeater
XF3		TB22 21	23_24V	Power supply for ch.23 serial repeater
XF4		TB23 2	24_24V	Power supply for ch.24 serial repeater
XF5		TB23 7	25_24V	Power supply for ch.25 serial repeater
XF6		TB23 12	26_24V	Power supply for ch.26 serial repeater
XF7		TB23 17	27_24V	Power supply for ch.27 serial repeater
XF8		TB23 22	28_24V	Power supply for ch.28 serial repeater
XF9		TB24 5 (TB23 23)	STA PWR	Power supply for STA step repeater
XF10		TB24 10	STB PWR	Power supply for STB step repeater
XF11		TB24 15	STC PWR	Power supply for STC step repeater
XF12		TB25 5	STD PWR	Power supply for STD step repeater
XF13		TB25 10	STE PWR	Power supply for STE step repeater
XF14		TB25 15	STF PWR	Power supply for STF step repeater
XF101	10 A	TB1 1	G1_24V PWR	Power from Gyro 1 Control unit +24V DC
XF102		TB2 1	G2_24V PWR	Power from Gyro 2 Control unit +24V DC
XF103	3.15 A			Not used

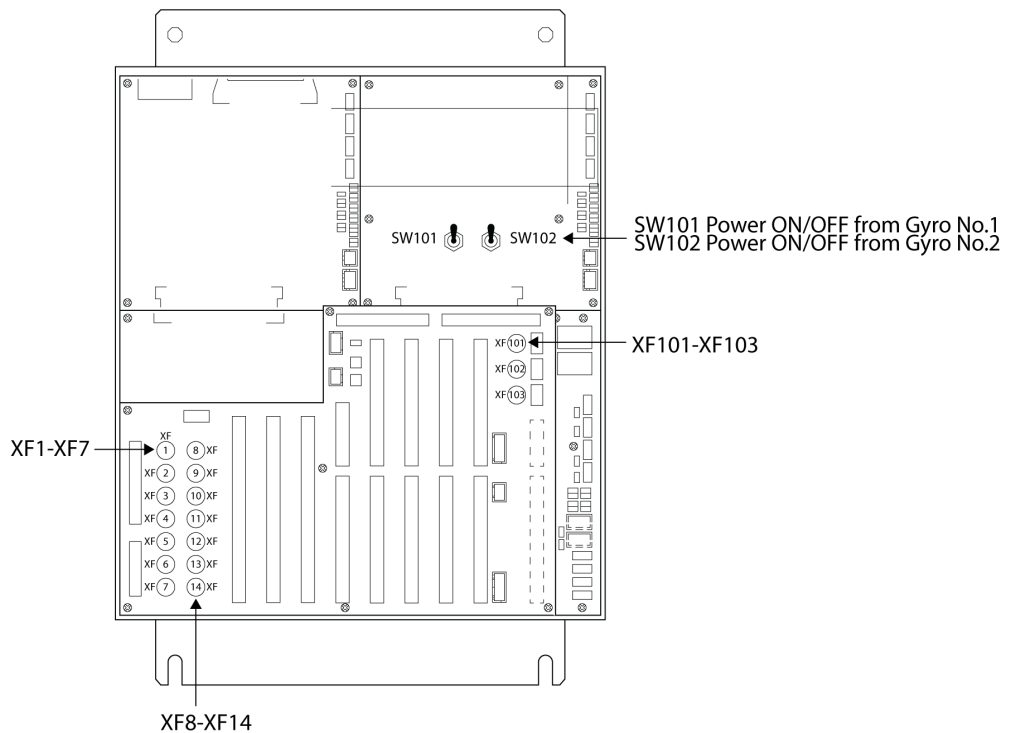

**WARNING**

**Main power can cause electric shock. Do not touch any terminal boards, even if unit power is OFF.**

**Caution**

*If a fuse is blown, replace it. Before replacing, make sure turn "OFF" the power and disconnect the main power and the battery power fed from the vessel's distribution board.*

- 1 Turn OFF the switch (breaker) fed from the vessel's power (AC/DC power).
- 2 If a fuse is blown, check the cause. Even though it is replaced with the same capacity fuse and it works, the fuse is blown again unless the cause is cleared. Consider that each fuse has certain different characteristics in spite of the same capacity fuse.
- 3 To remove the holder cap, turn counterclockwise while pushing the top of the fuse holder. Fuse is attached to the holder cap.

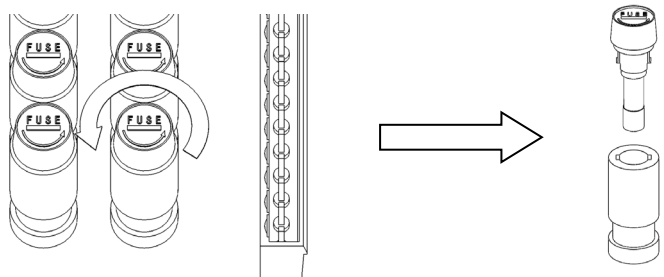

- 4 Check if the fuse is blown:
  - You can see the elements inside the glass fuses.
  - If the elements are cut, the fuse is blown.

- 5 If the fuse is blown, replace it.
- 6 Insert the fuse into the holder cap and into the fuse holder.
- 7 Turn clockwise while pushing down slowly.
- 8 When the fuse is inserted normally, the fuse holder is locked.

## 5.9 Storage and disposal methods

### Storage

- 1 Turn "OFF" all power switches.
- 2 Storage temperature should be kept in the range of -20°C to +55°C.
  - Do not keep the system in a place with high humidity to protect it from rusting.
- 3 Keep corrosive gas, breed bacteria, insects, or small animals away from the storage area.
- 4 Cover the system with plastic sheets or equivalents to keep away dust.
- 5 When welding works are carried out near the system, be sure to cover it with suitable protective sheets to prevent damage from sparks.

### Disposal

Dispose of the system in a proper manner as an industrial waste product in accordance with the relevant laws and regulations.

## 5.10 Heading sensor parameter check

On the main screen, press MENU/NO.1 key to open the display menu list in the upper left corner.



- 1 Press  $\Delta$ /NO.2 key or  $\nabla$ /EXT key and move the yellow frame to <DATA>.
- 2 Press SET/ENT key to display the connected heading sensor.

- 3 Press  $\Delta$ /**NO.2** key or  $\nabla$ /**EXT** key and move the yellow frame to the selected heading sensor.

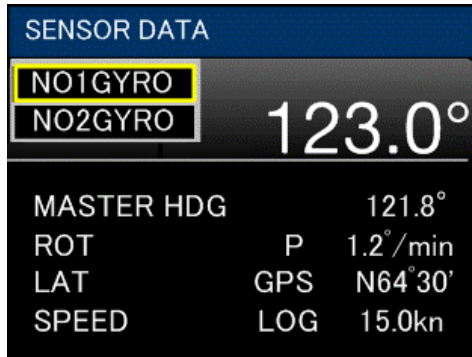

- 4 Press **SET/ENT** key to display the heading of the gyrocompass, rate of turn, latitude, and vessel's speed input.

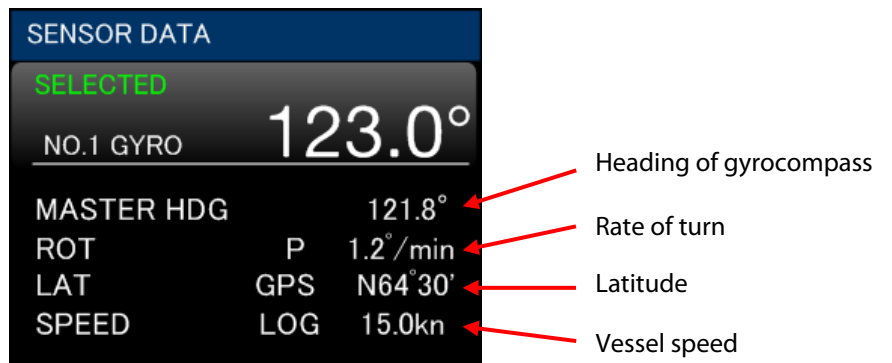

## 6 INSTALLATION

This section is a reference guide to correctly install and configure the GC80/85 Double System Controller unit.

The installation must be performed by a SIMRAD certified technician.

For installation and setup of GC80/85 Expanded systems, please refer to separate manual.

### 6.1 Unpacking and handling

Care should be taken when unpacking and handling the equipment. A visual inspection should be made to see that the equipment has not been damaged during shipment and that all components and parts are included.

### 6.2 Mechanical installation

The units included in the GC80/85 Double System Controller unit should be mounted with special regard to the units' environmental protection, temperature range, and cable length. Refer *TECHNICAL SPECIFICATIONS*, page 34 onwards.

#### Control unit

The control unit is bulkhead mounted by using 4 bolts as shown in the illustration.

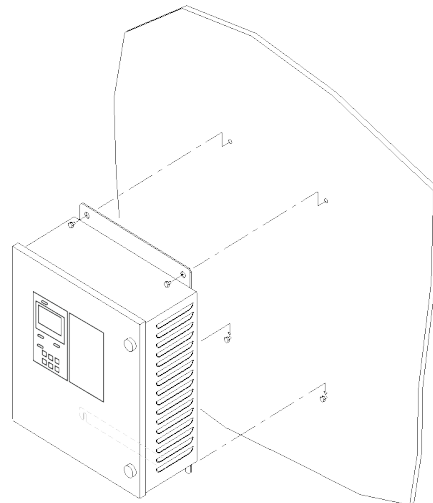

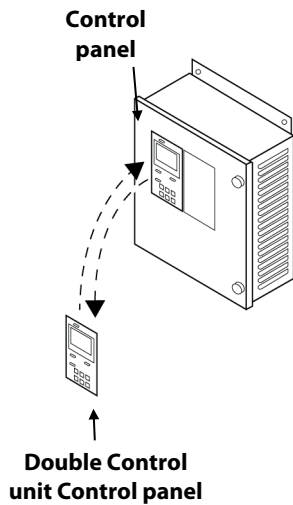

### Flush mounting the control panel

The control panel may be removed from the control unit and mounted in a remote location by using the optional flush mounting kit (part number 000-15844-001).

The flush mounting kit includes:

- 1 blind panel for Double CP ext. mounting (part no: 000-15832-001)
- 1 frame for Double CP ext. mounting (part no: 000-15833-001)
- 1 harness for Double CP ext. mounting 2.8 m cable (part no: 000-15834-001)

Use the following procedure when remotely mounting the control panel:

- 1** Unplug J71 from the ANNM board.
- 2** Loosen the 4 screws holding the control panel and remove the panel from the front. Reuse the screws and mount the blind panel from the remote mounting kit to the Control unit front/door.
- 3** Mount the Control panel in the mounting frame from the remote mounting kit using 4 screws. The mounting frame must already be mounted in the console.
- 4** Insert the plug on the 2.8 m cable, from the remote mounting kit, to J71 on ANNM board and use terminal connectors and installation cable to connect it to TB3 1-7 in the Double Control unit.

Refer to separate drawings for cable connections.

## 6.3 Cabling

Note!

*No cables are included when the gyro system is delivered from factory.*

The wiring diagrams on page 40 onwards include cable specifications for all cables.

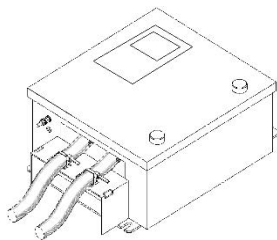

Connect the power and the signal cables according to the wiring diagrams on page 40 onwards.

To avoid cables to loosen due to vibration, the cables could be fastened to the fixing device using wire strips as illustrated in the figure.

## Power supply

The GC80/85 Double Control unit is powered from the two GC80/85 Expanded gyro systems and does not need to be connected to any additional external power source.

## 6.4 Grounding the unit

The Double Control unit should have a proper ground connection from the unit's ground terminal (**A**).

The wires should be as short as possible and have a cross section of at least AWG13 (2.5 mm<sup>2</sup>).

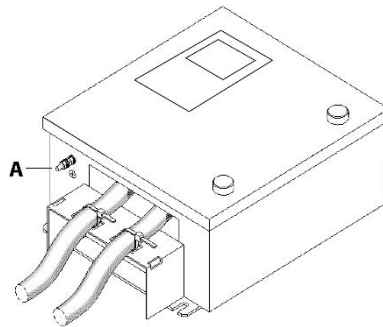

**DOUBLE SYSTEM CONTROLLER UNIT**

## 6.5 DIP switch and jumper settings

The GC80 and GC85 Double System Controller units include several DIP switches and jumpers. With the exception of 2 switches on the SCC board in the control unit, no switches have to be set when installing the system. These 2 switches are set to configure the control unit to match the type of gyro system (GC80 or GC85).

Note!

*All DIP switch settings are read when the system is started. Any changes made while the system is running will therefore not take effect until the system is restarted.*

For a complete list of DIP switch settings, refer to "DIP SWITCH SETTINGS", page 56.

## Activating the GC80 or GC85 Double System Controller unit



When the gyro system is shipped from factory, all DIP switches in the control unit are set as a standard GC80 system.

Before the system is started, the switch settings described below have to be changed to match a GC85 system.

DIP switch NO.2 on S1 on the SCC board identifies the gyro as a GC80 or GC85 system.

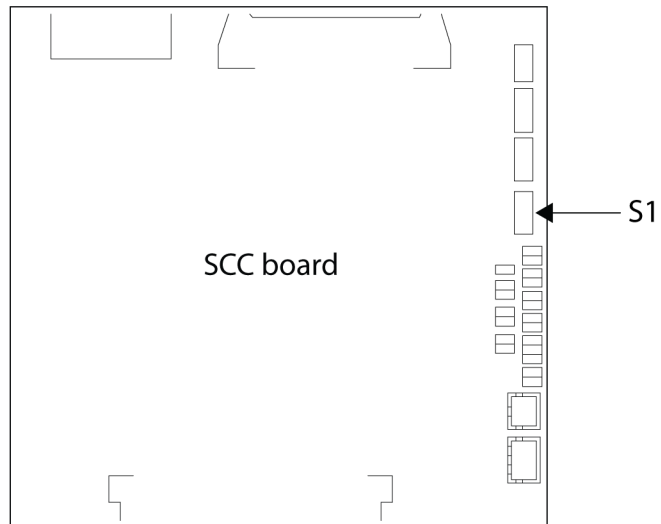
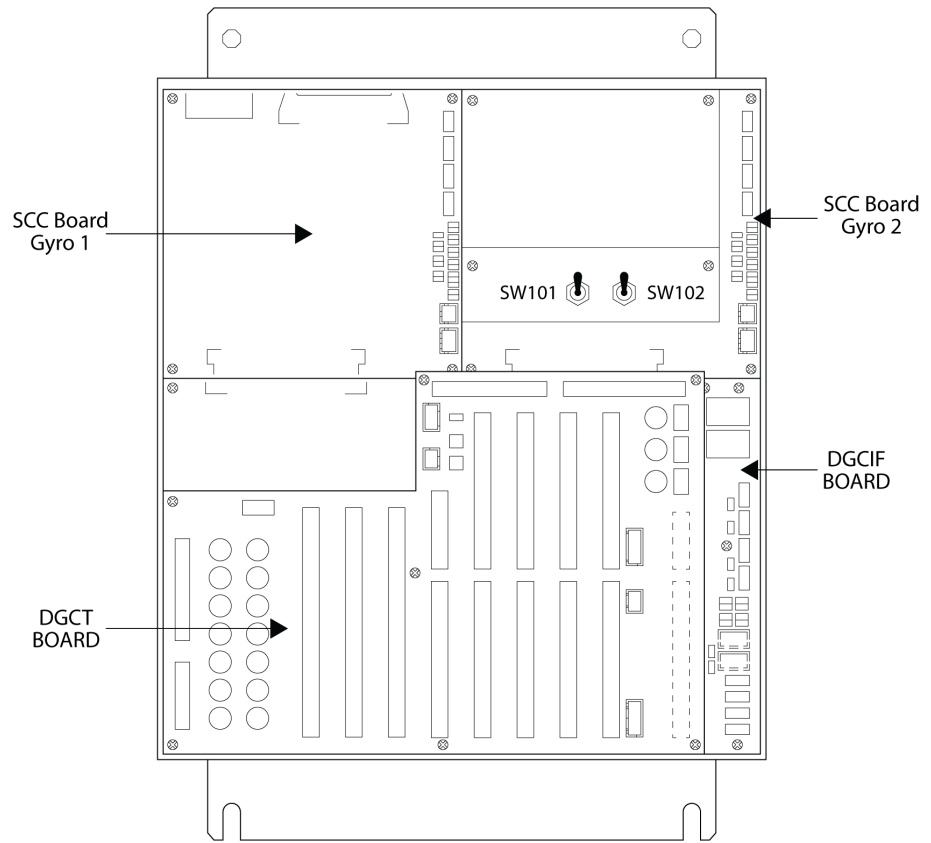
Simrad GC80/85 Double System Controller





GC80 system	GC85 system
 <p>ON S1</p>	 <p>ON S1</p>

## 6.6 Activating or deactivating the automatic switch

The Double Gyro system can have manual switch/selection of gyro sensor or automatic switching when one of the gyro sources fails.

Selection is done by S1-8 on the DGCIF board located under the DGCT board.

Manual switching	Automatic switching
 <p>ON S1</p>	 <p>ON S1</p>

## 6.7 Expanded Control unit settings in a Double gyro system

When the Expanded Control unit is used with the Double System Controller unit the following SCC PCB DIP switch settings are used.

Expanded Control Unit			
SCC Board Gyro 1		SCC Board Gyro 2	
Switch	Settings	Switch	Settings
S1-3	ON	S1-3	ON
S1-4	OFF	S1-4	ON
S1-5	OFF	S1-5	OFF
S1-6	OFF	S1-6	OFF
S4-6	ON	S4-6	ON

## 6.8 Parameter settings

This section explains how to set the parameters.

- 1 On the main screen, press **MENU/NO.1** key to open the display menu list in the upper left corner.



- 2 Press **Δ/NO.2** or **∇/EXT** key and move the yellow frame to <SET>.
- 3 Press **SET/ENT** key to display the setting parameters.



- 4 Press **SET/ENT** key. The setting value starts blinking.
- 5 Press **Δ/NO.2** or **∇/EXT** key to change the value.
- 6 Press **SET/ENT** key to confirm the setting value.

PARAMETER	DESCRIPTION
Gyro diff. alert	Set the threshold level of the gyrocompass heading difference alert. Adjustment range: 3.5 – 15.0 [deg.]. When the difference between two gyrocompasses exceeds the threshold level, an alert is activated.
Date/time	This setting cannot be changed by the user. Display UTC from GNSS.

## 7 TECHNICAL SPECIFICATIONS

This section lists all specifications for the GC80/85 Double System Controller unit.

### 7.1 General specifications

Repeater type: ..... 24 V DC - 6 step/°  
 Number of step repeater connections: ..... 6  
 Number of NMEA connections: ..... 18

#### Function:

- NO.1/NO.2 gyrocompass true heading display.
- Rate of turn display.
- True heading output.
- Rate of turn output.
- Alert history/details display.

#### Display Unit

Size	3.5 inches
Effective display range	70.56 mm x 52.92 mm
Resolution	320 x 240 dot, QVGA
Dot pitch	0.0735 mm x 0.2205 mm (W x V)

#### Input signal

- Serial signal (Based on IEC-61162-1/2).
- True heading information of NO.1/NO.2 gyrocompass.

#### Output signal

- Serial signal (Based on IEC-61162-1/2).
- True heading information of the selected gyrocompass.
- Step signal.
- Rate of turn analog signal.

#### Power

- Main power:  
 24 V DC +30% -20%, 250 V A (MAX) (from NO. 1/2 Gyro compass system)

- Battery power:  
24 V DC +30% -20%, 75 V A (MAX)

**Operating Conditions**

- Specified operating conditions:  
Temperature: -15 - +55°C  
Humidity: 95% RH (40°C) or less
  
- Recommended operating conditions  
Temperature: 0 - +45°C  
Humidity: 95% RH (35°C) or less

**7.2 Input specifications**

Serial input signal (GPS)

Circuits: ..... 2  
 Electrical: .....RS422/ NMEA0183  
 Baud rate: ..... 4800 bps  
 Data bits: .....8 bits  
 Parity:.....None  
 Stop bits:..... 1  
 Transmit freq.:..... 1 Hz  
 Input format:  
 \$--GGA,x,xx,x,N,xx,x,E,x,~\*hh<CR><LF> \*  
 \$--GLL,xxxx,xx,N,xxxx,xx,E~\*hh<CR><LF>  
 \$--VTG,xx,T,xx,M,xx,x,N,xx,K\*hh<CR><LF>  
 \$--ZDA,xxxxxx,xx,xx,xxxx,xx,xx\*hh<CR><LF>

\* Priority

Serial input signal (LOG)

Circuits: ..... 2  
 Electrical: .....RS422/NMEA0183  
 Baud rate: ..... 4800 bps  
 Data bits: .....8 bits  
 Parity:.....None  
 Stop bits:..... 1  
 Transmit freq.:..... 1 Hz  
  
 Input format:  
 \$--VBW,xx,x,x,A,xx,x,x,A~\*hh<CR><LF>  
 \$--VHW,xx,x,T,xx,x,M,xx,x,N,xx,x,K\*hh<CR><LF>

INS (BAMS)

Circuits: ..... 1  
Electrical: .....RS422/ NMEA0183  
Baud rate:..... 4800 bps  
Data bits: .....8 bits  
Parity:.....None  
Stop bits:..... 1  
Transmit freq.:.....INDETERMINATELY  
Input format:  
\$--ACN,xxxxxx.xx,aaa,x.x,x.x,aC\*hh<CR><LF>  
\$--HBT,x.x,a,x\*hh<CR><LF>

PULSE signal (LOG)

Circuits: ..... 1  
Electrical: .....200/400 p.p.n.m., dry contact  
Voltage/Current:..... 5 V/5 mA

Heading sensor select

Circuits: ..... 2  
Voltage/Current:.....32 V/20 mA

Alarm ACK

Circuits: ..... 1  
Voltage/Current:..... 5 V/5 mA

Buzzer stop

Circuits: ..... 1  
Voltage/Current:..... 5 V/5 mA

### 7.3 Output specifications

#### Serial output signal

Circuits: ..... 18  
 Electrical: ..... RS422/485  
 Baud rate: ..... 4800 / 38400 bps  
 Data bits: ..... 8 bits  
 Parity:.....None  
 Stop bits:..... 1  
 Transmit freq.:..... 5, 10, 50 Hz

#### Output format:

Data no.1  
 \$--HEHDT,xxx,x,T\*hh<CR><LF>  
 Data no.2  
 \$--HETHS,xxx,x,a\*hh<CR><LF>  
 Data no.3  
 \$--HEROT,xxx,x,a\*hh<CR><LF>  
 Data no.4  
 \$HEHCR,x,x,a,a,x,x\*hh<CR><LF>  
 Data no.5  
 \$HENSR,a,A,,,,,,,,\*hh<CR><LF>  
 Data no.6  
 \$--PTKM,HEALM,xxxx,x,xx\*hh<CR><LF>

#### INS (BAMS)

Circuits: ..... 1  
 Electrical: ..... RS422/NMEA0183  
 Baud rate: ..... 4800 / 38400 bps  
 Data bits: ..... 8 bits  
 Parity:.....None  
 Stop bits:..... 1  
 Transmit freq.:

Data no.1: ..... 30 s  
 Data no.2, 3:..... INDETERMINATELY  
 Data no.4: ..... 10 s

#### Output format:

Data no.1  
 \$--HEALC,x,x,x,x,x,aaa,x,x,x,x,x... ..\*hh<CR><LF>  
 Data no.2  
 \$--HEALF,x,x,x,xxxxxx.xx,a,a,a,aaa,x,x,x,x,  
x,x,a---a\*hh<CR><LF>  
 Data no.3  
 \$--HEARC,xxxxxx,aaa,x,x,x,a\*hh<CR><LF>  
 Data no.4  
 \$--ALR,xxxxxx.xx,xxx,a,a,a---a\*hh<CR><LF>



## 7.6 Environmental specifications

### **GC80/85 Double System Controller unit**

Enclosure material: .....Aluminum

Environmental protection:.....IP22

Color: ..... Black

Temperature range:

Operating:..... -15 - +55°C (5 - 131°F)

Storage:..... -20 - +55°C (-4 - 131°F)

## 8 DRAWINGS

This section contains dimensional drawings that show mechanical dimensions of the Double System Controller unit, together with wiring diagrams of the gyro system.

### 8.1 Drawings included

The following mechanical drawings are enclosed:

Name	Rev.
GC80/85 Double System Controller unit, dimensions	A
GC80/85 Remote panel, dimensions	B

The following wiring diagrams are enclosed:

Name
GC80/85 Double System Controller unit

Double System Controller unit dimensional drawing

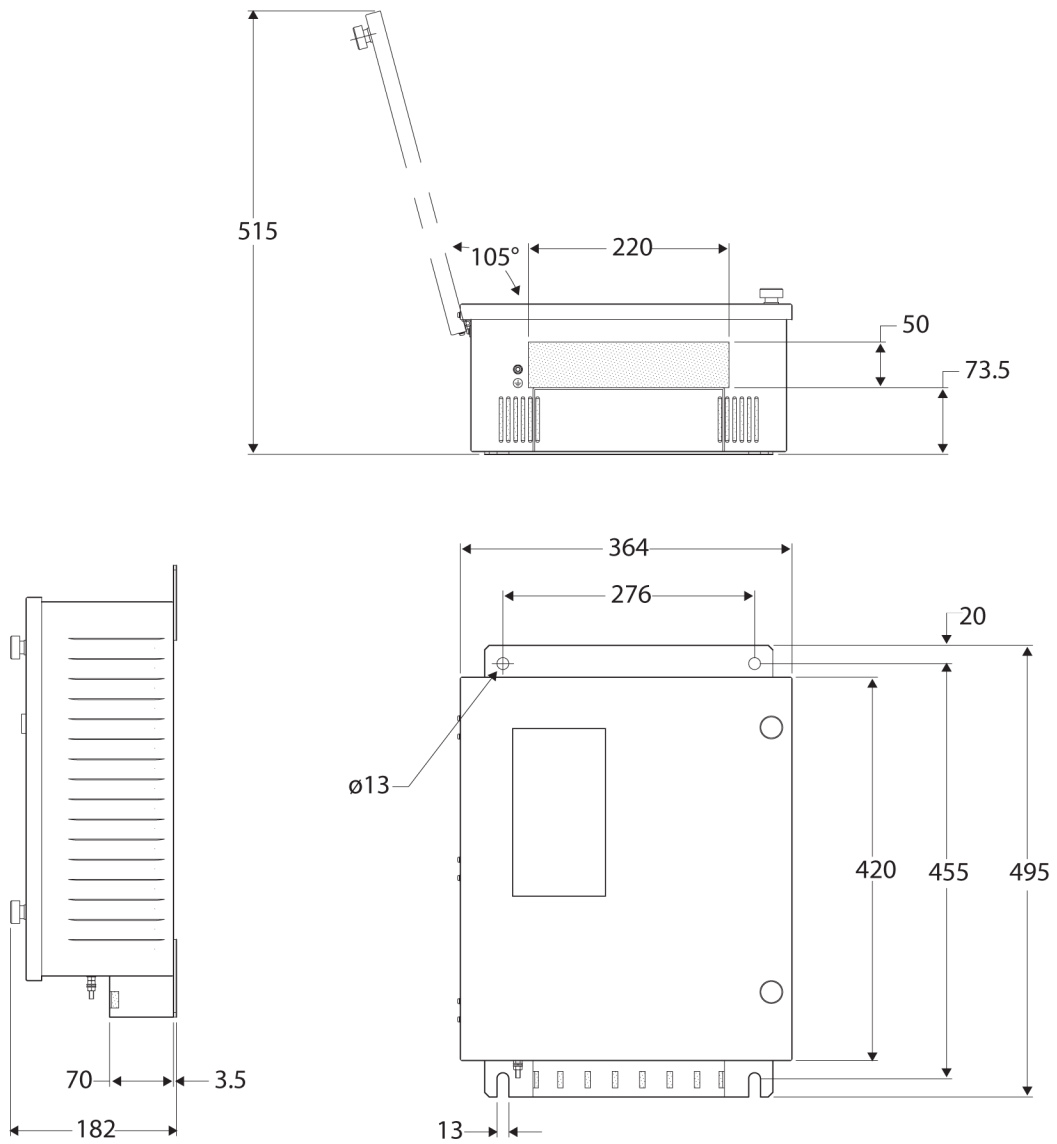

Remote panel dimensional drawing

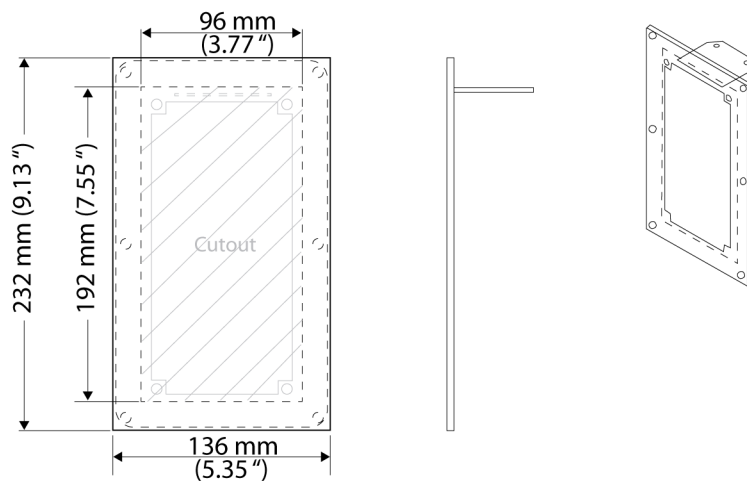

Simrad GC80/85 Double System Controller

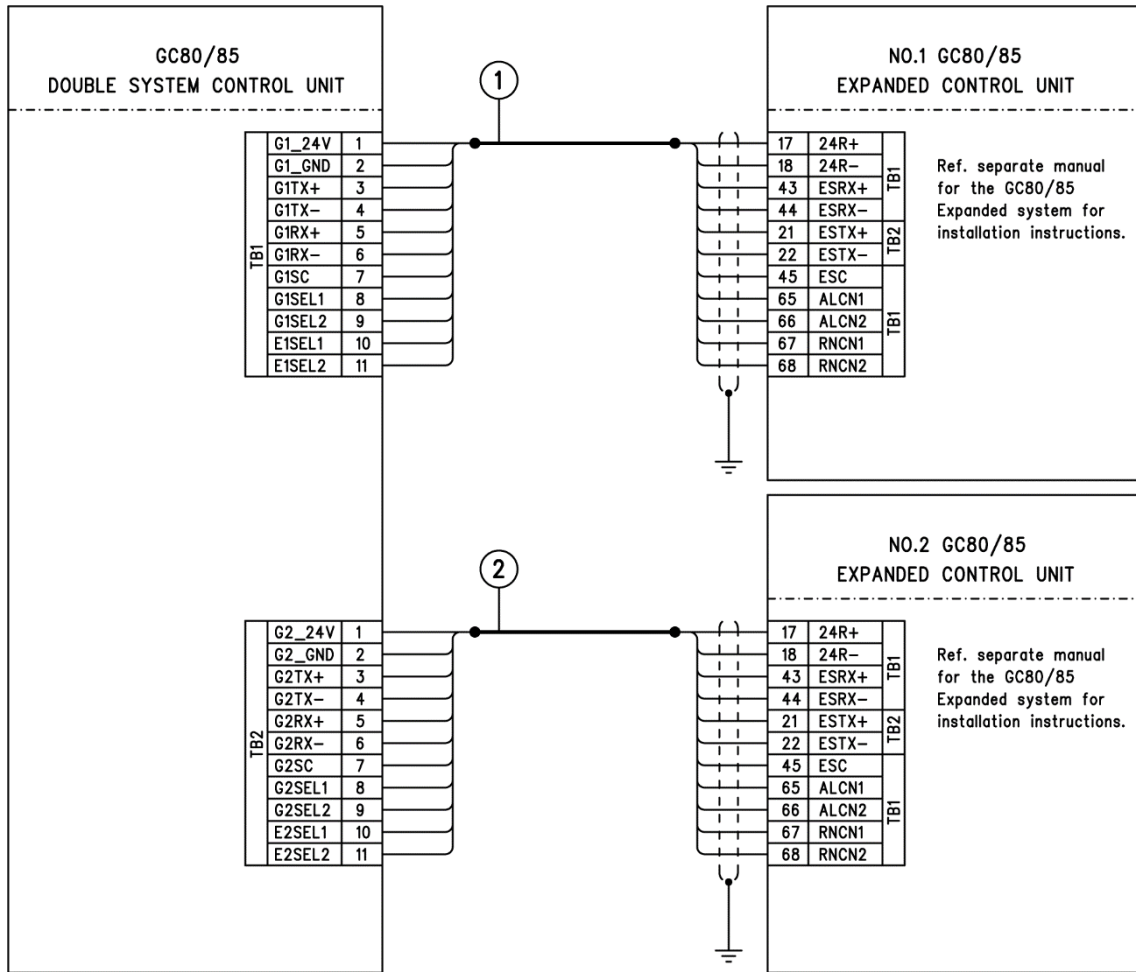

RECOMMENDED CABLE TYPES	
NO	CABLE TYPE
1-2	AWG17 SHIELDED

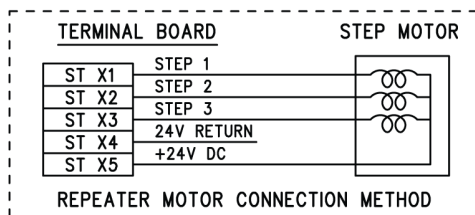
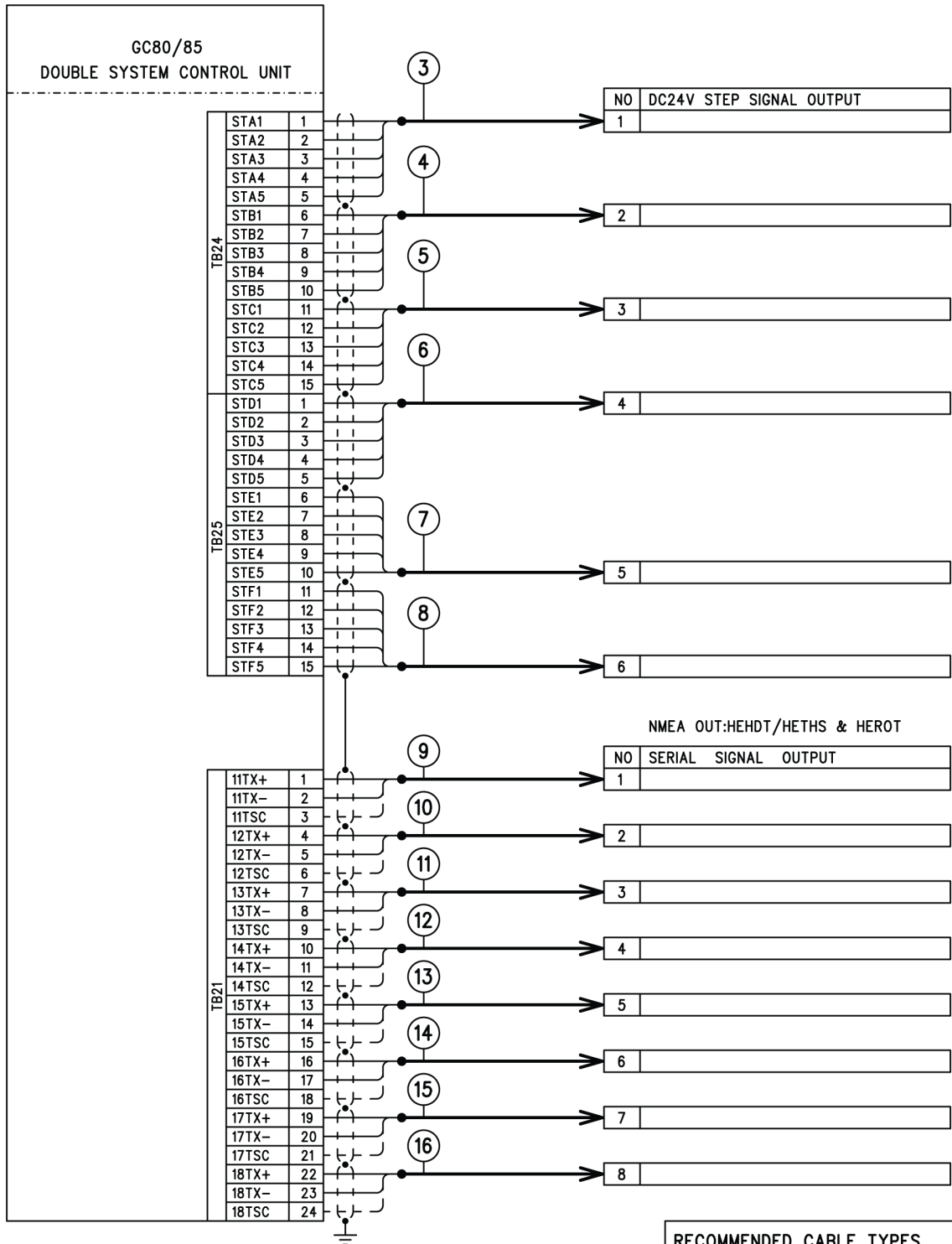

RECOMMENDED CABLE TYPES	
NO	CABLE TYPE
3-8	AWG17 SHIELDED
9-16	AWG18 TWISTED/SHIELDED

Simrad GC80/85 Double System Controller

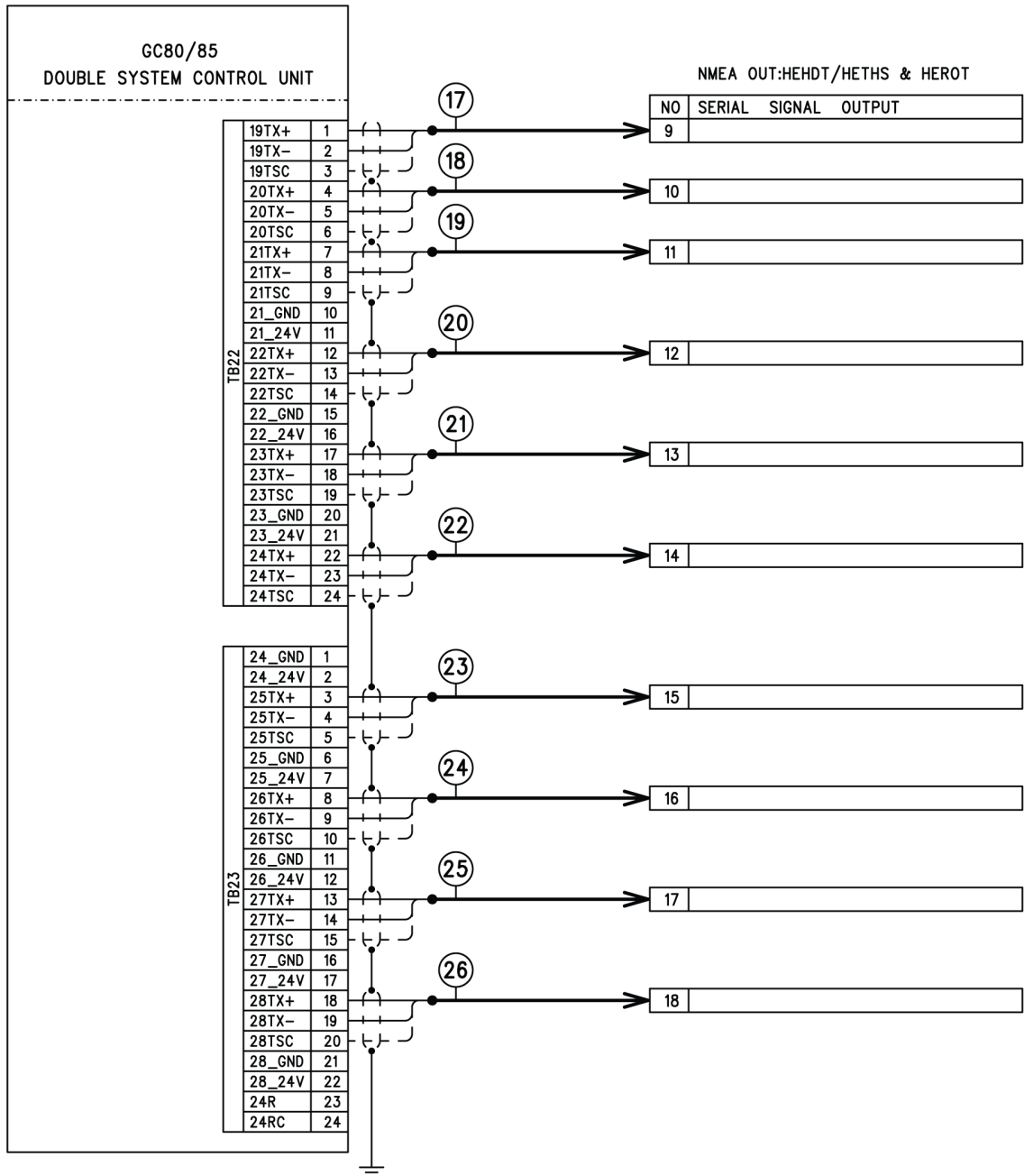

RECOMMENDED CABLE TYPES	
NO	CABLE TYPE
17-26	AWG18 TWISTED/SHIELDED

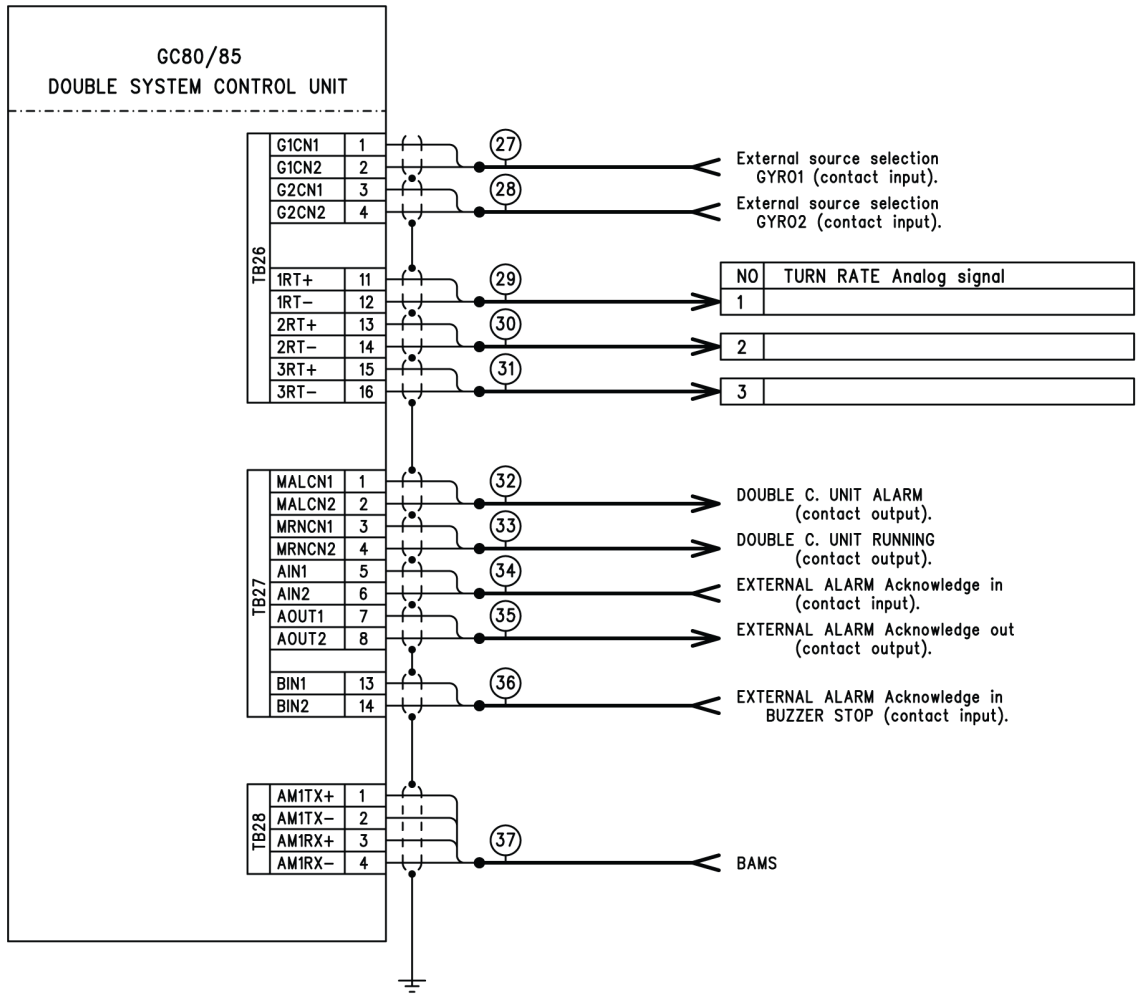

RECOMMENDED CABLE TYPES	
NO	CABLE TYPE
27-28	AWG17 SHIELDED
29-31	AWG18 TWISTED/SHIELDED
32-36	AWG17 SHIELDED
37	AWG18 TWISTED/SHIELDED

**Wiring when the Control panel is mounted outside the Control unit**

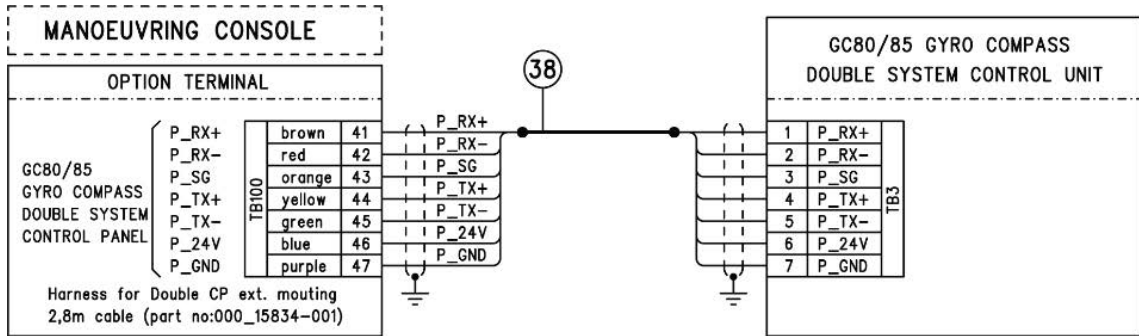

RECOMMENDED CABLE TYPES	
NO	CABLE TYPE
38	AWG18 TWISTED/SHIELDED

## 9 PART LIST

This section includes part numbers for all standard and optional units that may be included in a Double System Controller unit.

### 9.1 GC80/85 Double System Controller unit

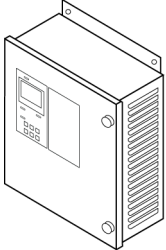
PART NO.		DESCRIPTION
000-15037-001		GC80/85 Double System Controller unit.
988-12719-00x		GC80/85 Double System Controller unit User manual.

### 9.2 GC80/85 optional equipment, Double System Controller unit

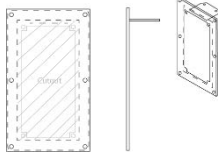
PART NO.		DESCRIPTION
000-15832-001		Remote mounting kit for Double Control panel. Including mounting frame, blind panel and harness (cable).

## 10 TERMINAL LAYOUT

This section includes tables that list all terminal pins and terminal labelling on the DGCT board in the GC80/85 Double System Controller unit. The tables include detailed descriptions of each terminal.

### 10.1 DGCT board

#### TB1

##### GYROCOMPASS NO.1

PIN NO	NAME	DETAILS
1	G1_24V	Power supply (24 V DC) (Repeater)
2	G1_GND	Power supply (24 V DC GND) (Repeater)
3	G1TX+	Internal communication serial signal output
4	G1TX-	
5	G1RX+	Internal communication serial signal input
6	G1RX-	
7	G1SC	Internal communication serial signal GND
8	G1SEL1	Selection signal input (potential free contact)
9	G1SEL2	
10	E1SEL1	External heading selection signal input (potential free contact)
11	E1SEL2	
12	G1ALCN1	Alert signal output (potential free contact)
13	G1ALCN2	
14	G1RNCN1	Running signal output (potential free contact)
15	G1RNCN2	
16	Not used	-

#### TB2

##### GYROCOMPASS NO.2

PIN NO	NAME	DETAILS
1	G2_24V	Power supply (24 V DC) (Repeater)
2	G2_GND	Power supply (24 V DC GND) (Repeater)
3	G2TX+	Internal communication serial signal output
4	G2TX-	
5	G2RX+	Internal communication serial signal input
6	G2RX-	

PIN NO	NAME	DETAILS
7	G2SC	Internal communication serial signal GND
8	G2SEL1	Selection signal input (potential free contact)
9	G2SEL2	
10	E2SEL1	External heading selection signal input (potential free contact)
11	E2SEL2	
12	G2ALCN1	Alert signal output (potential free contact)
13	G2ALCN2	
14	G2RNCN1	Running signal output (potential free contact)
15	G2RNCN2	
16	Not used	-

### TB3

PIN NO	NAME	DETAILS
1	P_RX+	Extension of operation panel internal communication serial signal input
2	P_RX-	
3	P_SC	Extension of operation panel internal communication serial signal GND
4	P_TX+	Extension of operation panel internal communication serial signal output
5	P_TX-	
6	P_24 V	Extension of operation panel power supply output 24 V DC
7	P_GND	Extension of operation panel power supply output GND
8		
9	P_G124 V	Not used
10	P_G1CN	
11	P_G224 V	
12	P_G2CN	
13	P_E24 V	
14	P_ECN	
15	P_GGND	
16	P_EGND	

**TB21**

PIN NO	NAME	DETAILS
1	11TX+	Serial signal output (RS422+): selected sensor
2	11TX-	Serial signal output (RS422-): selected sensor
3	11TSC	Serial signal output (GND)
4	12TX+	Serial signal output (RS422+): selected sensor
5	12TX-	Serial signal output (RS422-): selected sensor
6	12TSC	Serial signal output (GND)
7	13TX+	Serial signal output (RS422+): selected sensor
8	13TX-	Serial signal output (RS422-): selected sensor
9	13TSC	Serial signal output (GND)
10	14TX+	Serial signal output (RS422+): selected sensor
11	14TX-	Serial signal output (RS422-): selected sensor
12	14TSC	Serial signal output (GND)
13	15TX+	Serial signal output (RS422+): selected sensor
14	15TX-	Serial signal output (RS422-): selected sensor
15	15TSC	Serial signal output (GND)
16	16TX+	Serial signal output (RS422+): selected sensor
17	16TX-	Serial signal output (RS422-): selected sensor
18	16TSC	Serial signal output (GND)
19	17TX+	Serial signal output (RS422+): selected sensor
20	17TX-	Serial signal output (RS422-): selected sensor
21	17TSC	Serial signal output (GND)
22	18TX+	Serial signal output (RS422+): selected sensor
23	18TX-	Serial signal output (RS422-): selected sensor
24	18TSC	Serial signal output (GND)

**TB22**

PIN NO	NAME	DETAILS
1	19TX+	Serial signal output (RS422+): selected sensor
2	19TX-	Serial signal output (RS422-): selected sensor
3	19TSC	Serial signal output (GND)
4	20TX+	Serial signal output (RS422+): selected sensor
5	20TX-	Serial signal output (RS422-): selected sensor
6	20TSC	Serial signal output (GND)
7	21TX+	Serial signal output (RS422+): selected sensor

PIN NO	NAME	DETAILS
8	21TX-	Serial signal output (RS422-): selected sensor
9	21TSC	Serial signal output (GND)
10	21_GND	Power for repeaters GND
11	21_24 V	Power for repeaters 24 V DC
12	22TX+	Serial signal output (RS422+): selected sensor
13	22TX-	Serial signal output (RS422-): selected sensor
14	22TSC	Serial signal output (GND)
15	22_GND	Power for repeaters GND
16	22_24 V	Power for repeaters 24 V DC
17	23TX+	Serial signal output (RS422+): selected sensor
18	23TX-	Serial signal output (RS422-): selected sensor
19	23TSC	Serial signal output (GND)
20	23_GND	Power for repeaters GND
21	23_24 V	Power for repeaters 24 V DC
22	24TX+	Serial signal output (RS422+): selected sensor
23	24TX-	Serial signal output (RS422-): selected sensor
24	24TSC	Serial signal output (GND)

**TB23**

PIN NO	NAME	DETAILS
1	24_GND	Power for repeaters GND
2	24_24 V	Power for repeaters 24 V DC
3	25TX+	Serial signal output (RS422+): selected sensor
4	25TX-	Serial signal output (RS422-): selected sensor
5	25TSC	Serial signal output (GND)
6	25_GND	Power for repeaters GND
7	25_24 V	Power for repeaters 24 V DC
8	26TX+	Serial signal output (RS422+): selected sensor
9	26TX-	Serial signal output (RS422-): selected sensor
10	26TSC	Serial signal output (GND)
11	26_GND	Power for repeaters GND
12	26_24 V	Power for repeaters 24 V DC
13	27TX+	Serial signal output (RS422+): selected sensor
14	27TX-	Serial signal output (RS422-): selected sensor
15	27TSC	Serial signal output (GND)

PIN NO	NAME	DETAILS
16	27_GND	Power for repeaters GND
17	27_24 V	Power for repeaters 24 V DC
18	28TX+	Serial signal output (RS422+): selected sensor
19	28TX-	Serial signal output (RS422-): selected sensor
20	28TSC	Serial signal output (GND)
21	28_GND	Power for repeaters GND
22	28_24 V	Power for repeaters 24 V DC
23	24R	Power for repeaters +24V DC (spare)
24	24RC	Power for repeaters GND (spare)

### TB24

PIN NO	NAME	DETAILS
1	STA1	Step-to-step signal output (3 phased): selected sensor
2	STA2	Step-to-step signal output (3 phased): selected sensor
3	STA3	Step-to-step signal (3 phased): selected sensor
4	STA4	Power for repeaters GND
5	STA5	Power for repeaters 24 V DC
6	STB1	Step-to-step signal output (3 phased): selected sensor
7	STB2	Step-to-step signal output (3 phased): selected sensor
8	STB3	Step-to-step signal (3 phased): selected sensor
9	STB4	Power for repeaters GND
10	STB5	Power for repeaters 24 V DC
11	STC1	Step-to-step signal output (3 phased): selected sensor
12	STC2	Step-to-step signal output (3 phased): selected sensor
13	STC3	Step-to-step signal (3 phased): selected sensor
14	STC4	Power for repeaters GND
15	STC5	Power for repeaters 24 V DC
16	Not used	-

**TB25**

PIN NO	NAME	DETAILS
1	STD1	Step-to-step signal output (3 phased): selected sensor
2	STD2	Step-to-step signal output (3 phased): selected sensor
3	STD3	Step-to-step signal (3 phased): selected sensor
4	STD4	Power for repeaters GND
5	STD5	Power for repeaters 24V DC
6	STE1	Step-to-step signal output (3 phased): selected sensor
7	STE2	Step-to-step signal output (3 phased): selected sensor
8	STE3	Step-to-step signal (3 phased): selected sensor
9	STE4	Power for repeaters GND
10	STE5	Power for repeaters 24 V DC
11	STF1	Step-to-step signal output (3 phased): selected sensor
12	STF2	Step-to-step signal output (3 phased): selected sensor
13	STF3	Step-to-step signal (3 phased): selected sensor
14	STF4	Power for repeaters GND
15	STF5	Power for repeaters 24 V DC
16	Not used	-

**TB26**

PIN NO	NAME	DETAILS
1	G1CN1	NO.1 gyrocompass selection signal input (potential free contact)
2	G1CN2	
3	G2CN1	NO.2 gyrocompass selection signal input (potential free contact)
4	G2CN2	
5	ESCN1	Not used
6	ESCN2	
7	PRRX+	Heading control system serial signal input Not used
8	PRRX-	
9	PRSC	Heading control system serial signal input (GND)
10		
11	1RT+	Turn rate analog signal
12	1RT-	Turn rate analog signal GND
13	2RT+	Turn rate analog signal
14	2RT-	Turn rate analog signal GND
15	3RT+	Turn rate analog signal
16	3RT-	Turn rate analog signal GND

**TB27**

PIN NO	NAME	DETAILS
1	MALCN1	Change over unit alert output (potential free contact)
2	MALCN2	
3	MRNCN1	Change over unit running output (potential free contact)
4	MRNCN2	
5	AIN1	External alert acknowledging signal input potential free contact (Alert Ack.)
6	AIN2	
7	AOUT1	External alert acknowledging signal output potential free contact
8	AOUT2	
9	OPRCN1	Operation signal contact output
10	OPRCN2	
11	BNA1	Backup Navigation alert signal contact output (spare)
12	BNA2	
13	BIN1	External alert acknowledging signal input potential free contact (Buzzer stop)
14	BIN2	
15	MSPTX+	Serial signal output (RS422+): Spare
16	MSPTX-	Serial signal output (RS422-): Spare

**TB28**

PIN NO	NAME	DETAILS
1	AM1TX+	Alert transfer serial signal output (NO.1 CCRS) BAM
2	AM1TX-	
3	AM1RX+	Alert transfer serial signal input (NO.1 CCRS) BAM
4	AM1RX-	
5	AM1SC	Alert transfer serial signal GND (NO.1 CCRS)
6	AM2TX+	Alert transfer serial signal output (NO.2 CCRS) (spare)
7	AM2TX-	
8	AM2RX+	Alert transfer serial signal input (NO.2 CCRS) (spare)
9	AM2RX-	
10	AM2SC	Alert transfer serial signal GND (NO.2 CCRS)
11	BWTX+	BNWAS serial signal output (spare)
12	BWTX-	
13	BWRX+	BNWAS serial signal input (spare)
14	BWRX-	
15	BWSC	BNWAS serial signal GND
16		

**TB29**

PIN NO	NAME	DETAILS
1	GN1RX+	NO.1 GNSS serial signal input
2	GN1RX-	NO.1 GNSS serial signal input
3	GN1SC	NO.1 GNSS serial signal GND
4	GN2RX+	NO.2 GNSS serial signal input
5	GN2RX-	NO.2 GNSS serial signal input
6	GN2SC	NO.2 GNSS serial signal GND
7	LG1RX+	NO.1 SDME serial signal input
8	LG1RX-	NO.1 SDME serial signal input
9	LG1SC	NO.1 SDME serial signal GND
10	LG2RX+	NO.2 SDME serial signal input
11	LG2RX-	NO.2 SDME serial signal input
12	LG2SC	NO.2 SDME serial signal GND
13	LG1P1	NO.1 SDME vessel speed pulse input (200 P/NM)
14	LG1P2	NO.1 SDME vessel speed pulse input (200 P/NM)
15	LG2P1	NO.2 SDME vessel speed pulse input (200 P/NM)
16	LG2P2	NO.2 SDME vessel speed pulse input (200 P/NM)

Note!

*GPS and LOG can be connected to the Double System or the Expanded Control units. It is recommended to connect to the two Expanded Control units.*

**TB30**

PIN NO	NAME	DETAILS
1	SPTX+	Serial signal output (RS-422+): Spare
2	SPTX-	Serial signal output (RS-422-): Spare
3	SPTSC	Serial signal output (common)
4	SPCN1	Spare signal output (Potential free contact)
5	SPCN2	Spare signal output (Potential free contact)
6	SPIN1	Spare signal input (Potential free contact)
7	SPIN2	Spare signal input (Potential free contact)
8		

## 11 DIP SWITCH SETTINGS

This section includes drawings of the different printed circuits boards in the control unit that include jumpers and DIP switches.

### 11.1 Double System Controller unit

3 different boards in the Double System Controller unit have jumpers and/or DIP switches that may be used to configure the GC80/85 Double system.

The following pages include drawings that show the location of jumpers and/or DIP switches, together with a short description of the different settings.

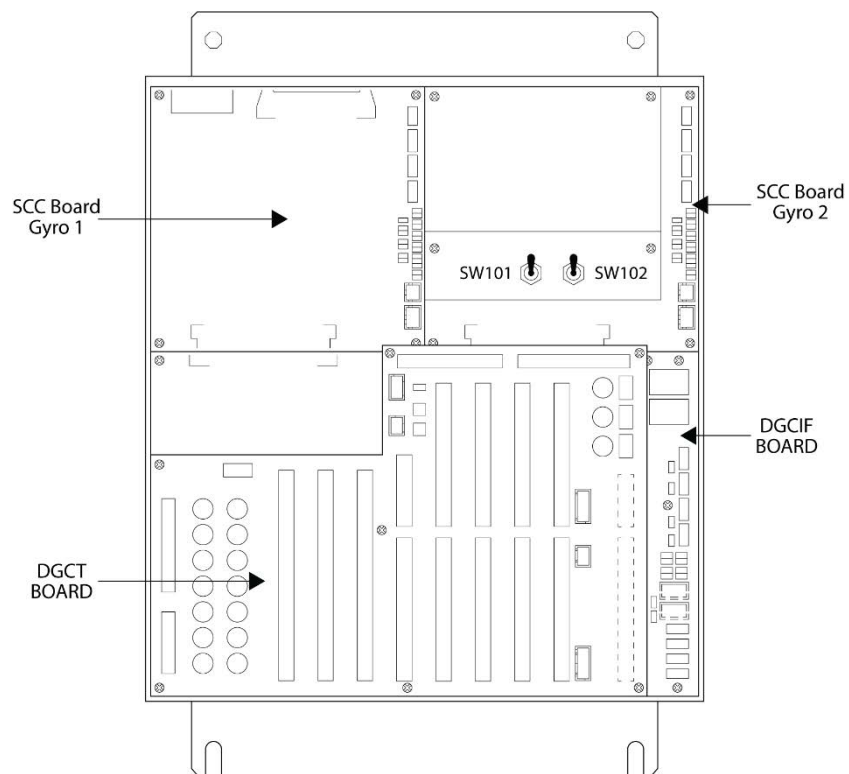

**DGCIF board**

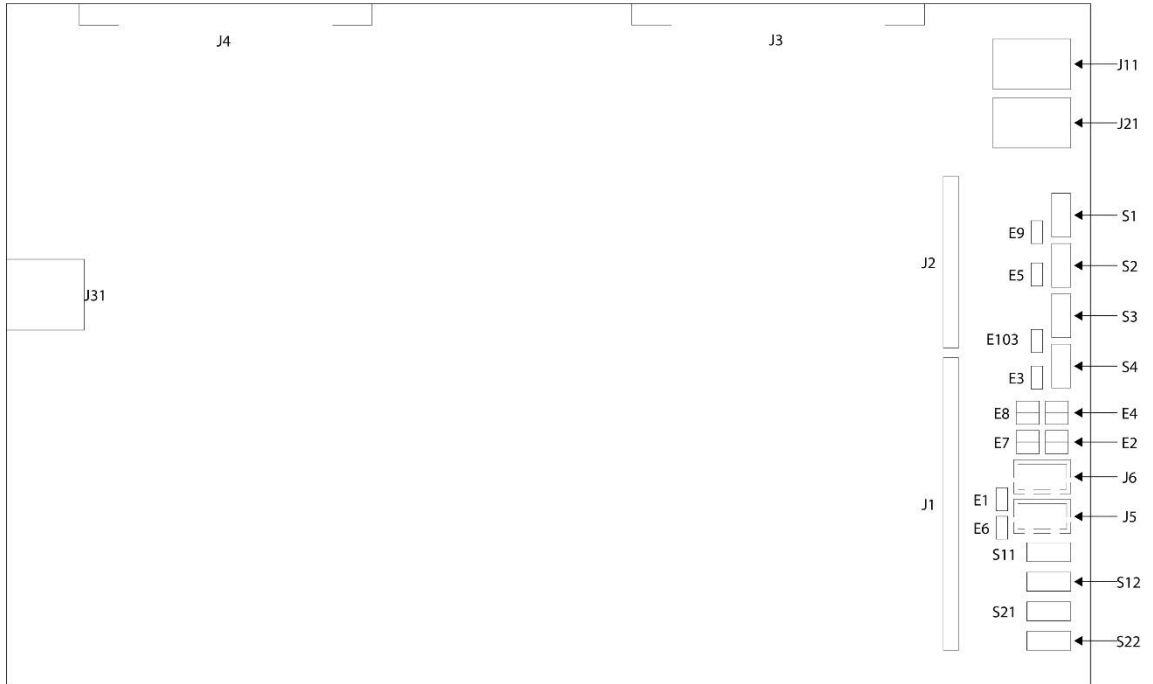

**Jumper settings on DGCIF board**

JUMPER	DEFAULT	FUNCTION	DESCRIPTION
E1	Short	NO.1 SCC software download	Software download (open for download)
E2	1-2 short	NO.1 setting of speed log pulse	1-2 short: 200 p.p.n.m. contact 3-4 short: 400 p.p.n.m. contact
E3	Short	NO.2 SCC software download	Software download (open for download)
E4	1-2 short	NO.2 setting of speed log pulse	1-2 short: 200 p.p.n.m. contact 3-4 short: 400 p.p.n.m. contact
E5	Open	CPU (U1) reset	CPU reset (short for CPU reset)
E6	Short	DGCIF (U1) software download	Software download (open for download)
E7	1-2 short	Setting of alert contact	1-2 short: Normal open/Alert closed 3-4 short: Normal closed/Alert open
E8	1-2 short	Setting of running contact	1-2 short: Running open/Stop closed 3-4 short: Running closed/Stop open
E9	Open	CPU (U2) reset	CPU reset (short for CPU reset)
E103	Short	DGCIF (U2) software download	Software download (open for download)

**DIP switch settings on DGCIF board**

<b>SWITCH</b>	<b>DEFAULT</b>	<b>FUNCTION</b>	<b>DESCRIPTION</b>
S1-1	OFF	Slave CPU	Must be OFF
S1-2	OFF	Do not touch	-
S1-3	OFF	Do not touch	-
S1-4	OFF	Do not touch	-
S1-5	ON	Do not touch	Must be ON -
S1-6	ON	TMC invalid	OFF = Valid ON = Invalid
S1-7	OFF	ALR sentence acceptable	OFF = Not acceptable ON = Acceptable
S1-8	ON	Automatic sensor/gyro selection valid	OFF = Invalid ON = Valid
S2-1	ON	NO.1 AMS connection	OFF = No connection ON = Yes
S2-2	OFF	NO.2 AMS connection	OFF = No connection ON = Yes
S2-3	OFF	Pilot connection Do not touch	-
S2-4	OFF	BNWAS connection Do not touch	-
S2-5	OFF	Do not touch	-
S2-6	OFF	Do not touch	-
S2-7	OFF	Do not touch	-
S2-8	OFF	Do not touch	-
S3-1	ON	Slave CPU	Must be ON
S3-2	OFF	Do not touch	-
S3-3	OFF	Do not touch	-
S3-4	OFF	Do not touch	-
S3-5	OFF	Do not touch	-
S3-6	OFF	Do not touch	-
S3-7	OFF	Do not touch	-
S3-8	OFF	Do not touch	-
S4-1	OFF	Do not touch	-
S4-2	OFF	Do not touch	-
S4-3	OFF	Do not touch	-
S4-4	OFF	Do not touch	-
S4-5	OFF	Do not touch	-
S4-6	OFF	Do not touch	-
S4-7	OFF	Do not touch	-
S4-8	OFF	Do not touch	-

SWITCH	DEFAULT	FUNCTION	DESCRIPTION
S11-1	OFF	NO.1 gyrocompass serial output setting	Output port: DGCIF board, TB21 "13TX+/-", NO.1 OFF = IEC61162-1 ed.4 output (4800 bps) ON = IEC61162-2 ed.1 output (38400 bps)
S11-2	OFF	NO.1 gyrocompass serial output setting	Output port: DGCIF board, TB21 "14TX+/-", NO.1 OFF = IEC61162-1 ed.4 output (4800 bps) ON = IEC61162-2 ed.1 output (38400 bps)
S11-3	OFF	NO.1 gyrocompass serial output setting	Output port: DGCIF board, TB21 "15TX+/-", NO.1 OFF = IEC61162-1 ed.4 output (4800 bps) ON = IEC61162-2 ed.1 output (38400 bps)
S11-4	OFF	NO.1 gyrocompass serial output setting	Output port: DGCIF board, TB21 "16TX+/-", NO.1 OFF = IEC61162-1 ed.4 output (4800 bps) ON = IEC61162-2 ed.1 output (38400 bps)
S11-5	OFF	NO.1 gyrocompass serial output setting	Output port: DGCIF board, TB21 "17TX+/-", NO.1 OFF = IEC61162-1 ed.4 output (4800 bps) ON = IEC61162-2 ed.1 output (38400 bps)
S11-6	OFF	NO.1 gyrocompass serial output setting	Output port: DGCIF board, TB21 "18TX+/-", NO.1 OFF = IEC61162-1 ed.4 output (4800 bps) ON = IEC61162-2 ed.1 output (38400 bps)
S11-7	OFF	NO.1 gyrocompass serial output setting	Output port: DGCIF board, TB22 "19TX+/-", NO.1 OFF = IEC61162-1 ed.4 output (4800 bps) ON = IEC61162-2 ed.1 output (38400 bps)
S11-8	OFF	NO.1 gyrocompass serial output setting	Output port: DGCIF board, TB22 20TX+/-, NO.1 OFF = IEC61162-1 ed.4 output (4800 bps) ON = IEC61162-2 ed.1 output (38400 bps)
S12-1	OFF	NO.1 gyrocompass serial output setting	Output port: DGCIF board, TB22 "21TX+/-", NO.1 OFF = IEC61162-1 ed.4 output (4800 bps) ON = IEC61162-2 ed.1 output (38400 bps)
S12-2	OFF	NO.1 gyrocompass serial output setting	Output port: DGCIF board, TB22 "22TX+/-", NO.1 OFF = IEC61162-1 ed.4 output (4800 bps) ON = IEC61162-2 ed.1 output (38400 bps)
S12-3	OFF	NO.1 gyrocompass serial output setting	Output port: DGCIF board, TB22 "23TX+/-", NO.1 OFF = IEC61162-1 ed.4 output (4800 bps) ON = IEC61162-2 ed.1 output (38400 bps)
S12-4	OFF	NO.1 gyrocompass serial output setting	Output port: DGCIF board, TB22 "24TX+/-", NO.1 OFF = IEC61162-1 ed.4 output (4800 bps) ON = IEC61162-2 ed.1 output (38400 bps)

SWITCH	DEFAULT	FUNCTION	DESCRIPTION
S12-5	OFF	NO.1 gyrocompass serial output setting	Output port: DGCIF board, TB23 "25TX+/-", NO.1 OFF = IEC61162-1 ed.4 output (4800 bps) ON = IEC61162-2 ed.1 output (38400 bps)
S12-6	OFF	NO.1 gyrocompass serial output setting	Output port: DGCIF board, TB23 "26TX+/-", NO.1 OFF = IEC61162-1 ed.4 output (4800 bps) ON = IEC61162-2 ed.1 output (38400 bps)
S12-7	OFF	NO.1 gyrocompass serial output setting	Output port: DGCIF board, TB23 "27TX+/-", NO.1 OFF = IEC61162-1 ed.4 output (4800 bps) ON = IEC61162-2 ed.1 output (38400 bps)
S12-8	OFF	NO.1 gyrocompass serial output setting	Output port: DGCIF board, TB23 "28TX+/-", NO.1 OFF = IEC61162-1 ed.4 output (4800 bps) ON = IEC61162-2 ed.1 output (38400 bps)
S21-1	OFF	NO.2 gyrocompass serial output setting	Output port: DGCIF board, TB21 "13TX+/-", NO.2 OFF = IEC61162-1 ed.4 output (4800 bps) ON = IEC61162-2 ed.1 output (38400 bps)
S21-2	OFF	NO.2 gyrocompass serial output setting	Output port: DGCIF board, TB21 "14TX+/-", NO.2 OFF = IEC61162-1 ed.4 output (4800 bps) ON = IEC61162-2 ed.1 output (38400 bps)
S21-3	OFF	NO.2 gyrocompass serial output setting	Output port: DGCIF board, TB21 "15TX+/-", NO.2 OFF = IEC61162-1 ed.4 output (4800 bps) ON = IEC61162-2 ed.1 output (38400 bps)
S21-4	OFF	NO.2 gyrocompass serial output setting	Output port: DGCIF board, TB21 "16TX+/-", NO.2 OFF = IEC61162-1 ed.4 output (4800 bps) ON = IEC61162-2 ed.1 output (38400 bps)
S21-5	OFF	NO.2 gyrocompass serial output setting	Output port: DGCIF board, TB21 "17TX+/-", NO.2 OFF = IEC61162-1 ed.4 output (4800 bps) ON = IEC61162-2 ed.1 output (38400 bps)
S21-6	OFF	NO.2 gyrocompass serial output setting	Output port: DGCIF board, TB21 "18TX+/-", NO.2 OFF = IEC61162-1 ed.4 output (4800 bps) ON = IEC61162-2 ed.1 output (38400 bps)
S21-7	OFF	NO.2 gyrocompass serial output setting	Output port: DGCIF board, TB22 "19TX+/-", NO.2 OFF = IEC61162-1 ed.4 output (4800 bps) ON = IEC61162-2 ed.1 output (38400 bps)
S21-8	OFF	NO.2 gyrocompass serial output setting	Output port: DGCIF board, TB22 "20TX+/-", NO.2 OFF = IEC61162-1 ed.4 output (4800 bps) ON = IEC61162-2 ed.1 output (38400 bps)

SWITCH	DEFAULT	FUNCTION	DESCRIPTION
S22-1	OFF	NO.2 gyrocompass serial output setting	Output port: DGCIF board, TB22 "21TX+/-", NO.2 OFF = IEC61162-1 ed.4 output (4800 bps) ON = IEC61162-2 ed.1 output (38400 bps)
S22-2	OFF	NO.2 gyrocompass serial output setting	Output port: DGCIF board, TB22 "22TX+/-", NO.2 OFF = IEC61162-1 ed.2 output (4800 bps) ON = IEC61162-2 ed.1 output (38400 bps)
S22-3	OFF	NO.2 gyrocompass serial output setting	Output port: DGCIF board, TB22 "23TX+/-", NO.2 OFF = IEC61162-1 ed.4 output (4800 bps) ON = IEC61162-2 ed.1 output (38400 bps)
S22-4	OFF	NO.2 gyrocompass serial output setting	Output port: DGCIF board, TB22 "24TX+/-", NO.2 OFF = IEC61162-1 ed.4 output (4800 bps) ON = IEC61162-2 ed.1 output (38400 bps)
S22-5	OFF	NO.2 gyrocompass serial output setting	Output port: DGCIF board, TB23 "25TX+/-", NO.2 OFF = IEC61162-1 ed.4 output (4800 bps) ON = IEC61162-2 ed.1 output (38400 bps)
S22-6	OFF	NO.2 gyrocompass serial output setting	Output port: DGCIF board, TB23 "26TX+/-", NO.2 OFF = IEC61162-1 ed.4 output (4800 bps) ON = IEC61162-2 ed.1 output (38400 bps)
S22-7	OFF	NO.2 gyrocompass serial output setting	Output port: DGCIF board, TB23 "27TX+/-", NO.2 OFF = IEC61162-1 ed.4 output (4800 bps) ON = IEC61162-2 ed.1 output (38400 bps)
S22-8	OFF	NO.2 gyrocompass serial output setting	Output port: DGCIF board, TB23 "28TX+/-", NO.2 OFF = IEC61162-1 ed.4 output (4800 bps) ON = IEC61162-2 ed.1 output (38400 bps)

Note!

*Settings for S21 and S22 must be set identically to S11 and S12.*

### SCC boards

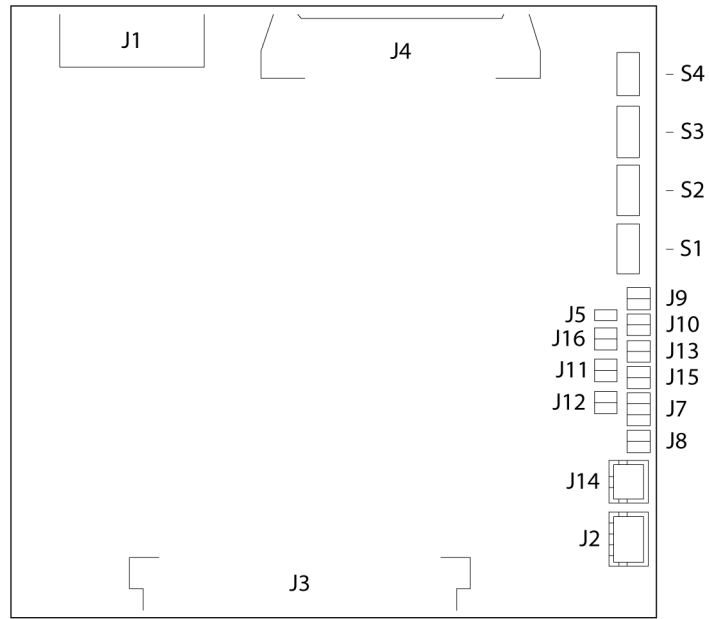

### DIP switch settings on SCC boards

SWITCH	DEFAULT	FUNCTION	DESCRIPTION		
S1-1	OFF	Control unit type	OFF = Expanded      ON = Compact		
S1-2	OFF	Master compass type	OFF = Standard      ON = High Speed		
S1-3	ON	2 Gyros used	OFF = Single      ON = Dual		
S1-4 <sup>1</sup>	OFF	Active gyro system	Note: Different settings for SSC board 1 and SSC board 2! Refer to footnote below.		
S1-4 <sup>2</sup>	ON				
S1-5	OFF	External sensor connection	SW1-5 OFF	= No external sensor	
			SW1-6 OFF		
S1-6	OFF		SW1-5 OFF	= Not used	
			SW1-6 ON		
S1-6	OFF		SW1-5 ON	= Not used	
			SW1-6 OFF		
S1-7	OFF		Serial signal format	SW1-5 ON	= Not used
				SW1-6 ON	
S1-7	OFF	Serial signal format	OFF = IEC61162-2 ed.1 (NMEA0183) ON = Tokimec		
S1-8	OFF	Alarm output setup	OFF = All alarms ON = Only power failures		

<sup>1</sup>SSC board 1 (for Gyro 1): OFF

<sup>2</sup>SSC board 2 (for Gyro 2): ON

SWITCH	DEFAULT	FUNCTION	DESCRIPTION	
S2-1	OFF	Data output for record (Not used)	SW2-1 OFF	No output
			SW2-2 OFF	
			SW2-1 OFF	Output for old monitor
			SW2-2 ON	
S2-2	OFF		SW2-1 ON	Output for new monitor
			SW2-2 OFF	
			SW2-1 ON	No output
			SW2-2 ON	
S2-3	OFF	Operating panel type	OFF = GPANEL (NOT FOR BAMS) ON = GPANEL-A (FOR BAMS)	
S2-4	OFF	Pendulum ferry	Not used	
S2-5	OFF	Serial signal transmit frequency IEC61162-1 ed.4	SW2-5 OFF	= 1 sec (1 Hz)
			SW2-6 OFF	
			SW2-5 OFF	= 100 msec (10 Hz) Note: If selecting 38400 baud rate for the serial out the output frequency will be: 50 Hz for HDT/THS and 50 Hz for ROT.
			SW2-6 ON	
S2-6	ON		SW2-5 ON	= 200 msec (5 Hz)
			SW2-6 OFF	
			SW2-5 ON	= Invalid
			SW2-6 ON	
S2-7	OFF	Not used		
S2-8	OFF	System select information contact	OFF = No	ON = Yes
S3-1	OFF	Timer startup	OFF = No	ON = Yes
S3-2	OFF	Talker ID of "ROT" sentence	OFF = "HE"	ON = "TI"
S3-3	ON	Rate of turn scale	SW3-3 OFF	Max 30.0 °/min.
			SW3-4 OFF	
			SW3-3 OFF	Max 300.0 °/min.
			SW3-4 ON	
S3-4	OFF		SW3-3 ON	Max 120.0 °/min.
			SW3-4 OFF	
			SW3-3 ON	Invalid
			SW3-4 ON	

SWITCH	DEFAULT	FUNCTION	DESCRIPTION
S3-5	OFF	Ban or permission of a "ROT" sentence output	Not used
3-6	ON	For Simrad use	OFF = Not used ON = Simrad GC type (80 or 85) shown in display at start-up according to S1-2 setting.
S3-7	OFF	Not used	
S3-8	OFF	Buzzer stop output/ Running contact output	OFF = Running contact enabled ON = Buzzer stop enabled
S4-1	OFF	Not used - Factory operation	
S4-2	ON	For Double System or not	OFF = Standard ON = Double
S4-3	OFF	Not used	
S4-4	OFF	Alarm detection time	OFF = 300 ms ON = 2 sec
S4-5	OFF	Enable/disable THS	OFF = HDT ON = THS
S4-6	ON	For Double system or not	OFF = Standard ON = Double

### Jumper settings on SCC boards

JUMPER	DEFAULT	FUNCTION	DESCRIPTION
J5 (RESET)	Open	CPU reset	Used to reset the CPU
J7 (11TX)	3-4 short	Serial signal output setting (DGCT board 11TX)	1-2 Short = TK spec. 3-4 Short = IEC61162-2 ed.1 (38400 bps) 5-6 Short = IEC61162-1 ed.4 (4800bps)  <i>NOTE: Never use both jumpers at the same time!</i>

JUMPER	DEFAULT	FUNCTION	DESCRIPTION
J8 (12TX)	3-4 short	Serial signal output setting (DGCT board 12TX)	1-2 Short = IEC61162-2 ed.1 (38400 bps) 3-4 Short = IEC61162-1 ed.4 (4800bps) <i>NOTE: Never use both jumpers at the same time!</i>
J9	1-2 short	Jumper for sensor selection signal	1-2 short: Normal open Short for selection 3-4 short: Unused
J10	1-2 short	Jumper for sensor selection signal	Output port: GTERM-A board, "RNCN" 1-2 Short = Running "CLOSES", Stop "OPEN" 3-4 Short = Running "OPEN", Stop "CLOSES" <i>NOTE: Never use both jumpers at the same time!</i>
J11	1-2 short	Not used	Not used
J12	1-2 short		
J13	1-2 short	Not used	Not used
J15	Open	Not used	Not used
J16	1-2 short	Not used	Not used

### DGCT board

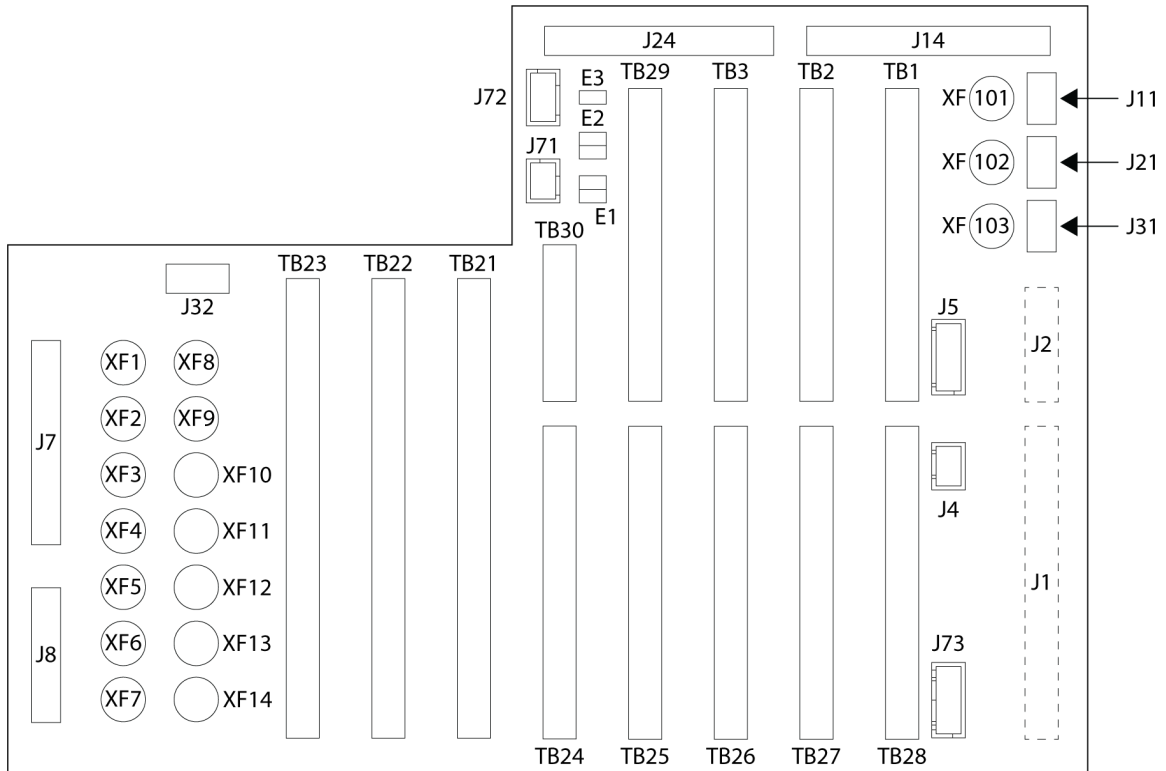

### Jumper settings on DGCT board

JUMPER	DEFAULT	FUNCTION	DESCRIPTION
E1	1-2 short 3-4 short	Connection of GPS to Double control unit	Both jumpers open = two GPS signal connected Both jumpers shorted = one GPS signal connected
E2	1-2 short 3-4 short	Connection of LOG to Double control unit (NMEA0183)	Both jumpers open = two LOG signal connected (NMEA0183) Both jumpers shorted = one LOG signal connected (NMEA0183)
E3	short	Connection of LOG pulse signals to Double control unit	Jumper open = two LOG signal connected (pulse signal) Jumper shorted = one LOG signal connected (pulse signal)

## 12 ALERT MESSAGES AND CORRECTIVE ACTIONS

This section provides a description of system errors and corrective actions that should be performed by the system operator.

### 12.1 The alert system

The GC80/85 system will continually check for faults while the system is running.

If any alarm is generated, verify the reason for the alarm.

If a fault occurs, an alert code will be displayed in the LCD. The alarm lamp will be flashing and an audible alarm will be activated.

Up to 4 alarm codes may be displayed in the LCD to indicate that several alarm situations are present. The last activated alarm will be displayed on the right side of the display. The figure below shows that alarm codes 1, 3 and 2 were generated in that order.

**Caution**

*When an alarm is generated, bearing information from the GC80/85 may not be present or may have large error. Any equipment using bearing information from the Gyro compass should therefore immediately be operated according to the equipment's emergency operating procedure.*

#### Alert display

Select <ALERT> in the display menu list to access the display.

In the alerts display, you can review the alert history and further details (date and cause).

#### Display when an alert occurs



For more details refer to “Complete alarm code lists” on page 72.

## Alert list

To access alert details (date and cause), press **MENU/NO.1** and select <ALERT>.

For more details refer to “Complete alarm code lists” on page 72.

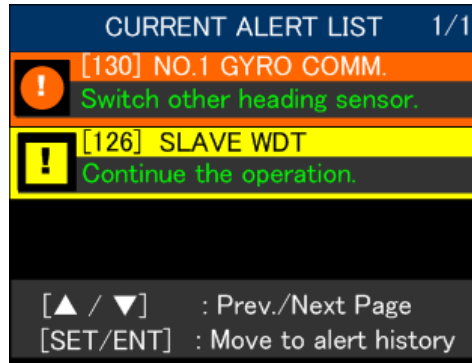

## Alert history

In the alert details, you can check the priority, the date, and the cause of the alert.

For more details refer to “Complete alarm code lists” on page 72.



## 12.2 Acknowledging an alert

When an alert is activated, check the system. Take appropriate measures after checking the navigational conditions around the vessel for safety and stopping at non-dangerous sea areas in principle.

Refer to “Complete alarm code list” on page 71.

### Operation when an alert is activated

This section explains the display and operation of the system when an alert is activated.

- 1 Alert is activated.
  - An alert window appears in the display’s lower/bottom line.
  - The total number of alerts is shown in the upper right corner.
  - The buzzer sounds.

Example of display when an alert is active:



- 2 Acknowledge the alert.
  - Read the message in the alert window and press the **ACK/ENT** key.
  - Press the **ACK/ENT** key to toggle between active alerts.

Example of display when several alerts are active:

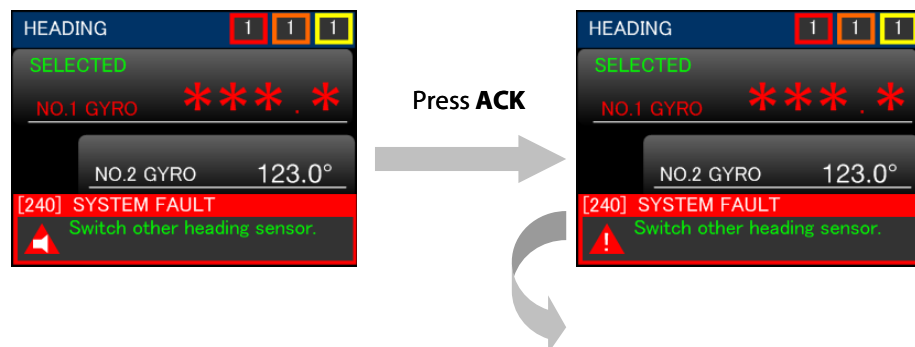

Press and hold **ACK** for 3 sec.



- 3** Alert is acknowledged.
- The alert window disappears.
  - The alert indicator stops blinking.
  - The buzzer stops.



- 4** Check the acknowledged alerts.
- After acknowledging the cause of the alert, you can check which alerts are still active.

Refer to “Check alert list and alert history” on page 71.

After acknowledging the alert, take appropriate measures following the operating guidance.

## Check alert screen

You can open the alert screen and display the acknowledged alerts.

- 1 Press the **MENU/NO.1** key to open the display menu list.



- 2 Press the **Δ/NO.2** key or the **▽/EXT** key to move the yellow frame to <ALERT> and press the **SET/ENT** key to confirm.
- 3 Active alerts are displayed in chronological order with the most recent ones at the top.

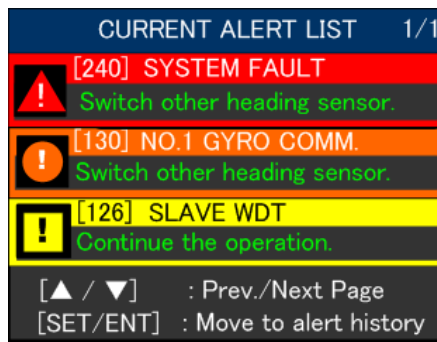

## Check alert list and alert history

After acknowledging the alert, you can check for active alerts and archived alerts.

Note!

*Alert history shows up to 32 archived alerts.*

- 1 Press the **MENU/NO.1** key to open the display menu list.



- 2 Press the **Δ/NO.2** key and the **∇/EXT** key to move the yellow frame to < ALERT >. Press the **SET/ENT** key to show the alert screen.
- 3 After acknowledging the alert, you can check for active alerts.

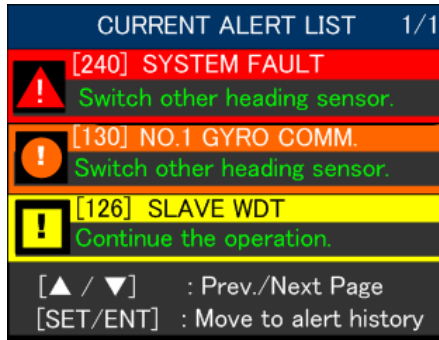

- Press the **Δ/NO.2** and the **∇/EXT** key to show more alerts.
- 4 Press the **SET/ENT** key to check archived alerts.



- The screen automatically returns to the main screen if there is no key operation for 30 seconds or more.
- 5 Press the **MENU/NO.1** key to go back to the current alert list.

## 12.3 Complete alarm code lists

### Alerts detected on Double

Alarm code	Name	Detailed code*1	Priority	Category	Troubleshooting
240	SYSTEM FAULT	E-1	Alarm Warning	B	TS-01
130	NO.1 GYRO COMM.	E-1	Alarm Warning Caution	B	TS-02
131	NO.2 GYRO COMM.	E-1	Alarm Warning Caution	B	TS-03

Simrad GC80/85 Double System Controller

Alarm code	Name	Detailed code*1	Priority	Category	Troubleshooting
101	NO.1 SCC COMM.	E-1	Alarm Warning	B	TS-05
102	NO.2 SCC COMM.	E-1	Alarm Warning	B	TS-06
100	PANEL COMM.	E-2	Warning	B	TS-07
107	DGCIF COMM.	E-1	Alarm Warning	B	TS-08
110	G1 PWR 24 V	E-2	Warning	B	TS-11
111	G2 PWR 24 V	E-2	Warning	B	TS-12
113	IF PWR NO.1 E5 V	E-2	Warning	B	TS-14
114	IF PWR NO.2 E5 V	E-2	Warning	B	TS-15
115	IF PWR DGC E5 V	E-2	Warning	B	TS-16
116	IF PWR NO.1 +12 V	E-2	Warning	B	TS-17
117	IF PWR NO.1 -12 V	E-2	Warning	B	
118	IF PWR NO.2 +12 V	E-2	Warning	B	TS-18
119	IF PWR NO.2 -12 V	E-2	Warning	B	
120	SENSOR SWITCH				TS-19
123	NO.1 SCC WDT	-	Caution	B	TS-20
124	NO.2 SCC WDT	-	Caution	B	
125	Master WDT	-	Caution	B	
126	Slave WDT	-	Caution	B	
134	GNSS comm.	E-2	Warning	B	
135	NO.1 GNSS comm.	E-2	Warning	B	
136	NO.2 GNSS comm.	E-2	Warning	B	
137	LOG comm.	E-2	Warning	B	
138	NO.1 LOG comm.	E-2	Warning	B	
139	NO.2 LOG comm.	E-2	Warning	B	
140	Pilot comm.	-	Caution	B	
141	INS comm.	-	Caution	B	
142	NO.1 INS comm.	-	Caution	B	
143	NO.2 INS comm.	-	Caution	B	
250	Integrity failed	E-2	Warning	B	TS-21
251	Integrity doubtful 1	E-2	Warning	B	TS-22
252	Integrity doubtful 2	E-2	Warning	B	TS-23

**Alert detected in GC80/85 Expanded No.1**

Alarm code	Name	Detailed code*1	Priority	Category	Troubleshooting
300	NO1GYRO MAIN PWR	E-2	Warning	A	TS-24
301	NO1GYRO PWR FAIL	E-2	Warning	A	
302	NO1GYRO INVERTER	E-2	Warning	A	
303	NO1GYRO CONT. PWR	E-2	Warning	A	
304	NO1GYRO ROTOR	E-2	Warning	A	
305	NO1GYRO LEVEL	E-2	Warning	A	
306	NO1GYRO SERVO	E-2	Warning	A	
307	NO1GYRO EEPROM	E-2	Warning	B	
308	NO1GYRO INN.COM1	E-2	Warning	A	
309	NO1GYRO INN.COM2	E-2	Warning	A	
310	NO1GYRO GPS COMM	E-2	Warning	B	
311	NO1GYRO GPS DATA	E-2	Warning	B	
312	NO1GYRO LOG COMM	E-2	Warning	B	
313	NO1GYRO LOG DATA	E-2	Warning	B	
318	NO1GYRO E5V	E-2	Warning	A	
319	NO1GYRO STEP ERR.	E-2	Warning	A	
320	NO1GYRO ZERO ERR.	E-2	Warning	B	
321	NO1GYRO DGC COMM	E-2	Warning	A	

**Alert detected in GC80/85 Expanded No.2**

Alarm code	Name	Detailed code*1	Priority	Category	Troubleshooting
500	NO2GYRO MAIN PWR	E-2	Warning	A	TS-24
501	NO2GYRO PWR FAIL	E-2	Warning	A	
502	NO2GYRO INVERTER	E-2	Warning	A	
503	NO2GYRO CONT.PWR	E-2	Warning	A	
504	NO2GYRO ROTOR	E-2	Warning	A	
505	NO2GYRO LEVEL	E-2	Warning	A	
506	NO2GYRO SERVO	E-2	Warning	A	
507	NO2GYRO EEPROM	E-2	Warning	B	
508	NO2GYRO INN.COM1	E-2	Warning	A	
509	NO2GYRO INN.COM2	E-2	Warning	A	
510	NO2GYRO GPS COMM.	E-2	Warning	B	

511	NO2GYRO GPS DATA	E-2	Warning	B	TS-24
512	NO2GYRO LOG COMM.	E-2	Warning	A	
513	NO2GYRO LOG DATA	E-2	Warning	B	
518	NO2GYRO E5V	E-2	Warning	A	
519	NO2GYRO STEP ERR.	E-2	Warning	A	
520	NO2GYRO ZERO ERR.	E-2	Warning	B	
521	NO2GYRO DGC COMM.	E-2	Warning	A	

\*1: Type of alert escalation:

E-1: If the warning is not acknowledged within a minute, the warning will escalate to Alarm.  
If not acknowledged within another 30 seconds, the alarm will be transmitted to BNWAS.

E-2: If the warning is not acknowledged within 1 minute, the warning indication will be kept and the buzzer sound is reactivated.

### Alarm priority list

Alarm priority		Description	Indication	Buzzer sound
High	A (Alarm)	Alarm requires immediate attention and action.  (The operator should switch to manual steering because the automatic steering may be unavailable).	Red	3 short beeps. Repeated every 7 seconds until the <b>ACK</b> button is pressed.
Middle	W (Warning)	Alarm requires immediate attention, but not immediate action.  (After acknowledging the alarm, take appropriate action. Some alarms escalate from middle to high priority if they are not acknowledged within a certain time.)	Yellowish orange	2 short beeps. Repeated every 60 seconds until the <b>ACK</b> button is pressed.
Low	C (Caution)	Alarms not categorized as High (A) priority or Middle (W) priority.  (The alarm does not influence the current steering. Recover it before switching from manual to automatic steering mode.)	Yellow	None

Note!

*This equipment does not have any High (A) priority alarms.*

※5: The description of Categories

Simrad GC80/85 Double System Controller

Category A	Alarm that can only be acknowledged ( <b>ACK</b> button) by operating the system.
Category B	Alarm that can be acknowledged ( <b>ACK</b> button) by operating either the system or external equipment (CAM-HMI).

## 13 TROUBLESHOOTING

### **TS-01 - System gyrocompass abnormality**

Procedure and treatment:

- 1 The alert is activated if a fatal abnormality occurs in the gyrocompass system.
- 2 Check operation of the selected gyrocompass.
- 3 If the gyrocompass is abnormal, switch to the other gyrocompass.
- 4 Fix the abnormality by following the operator manual of the gyrocompass.

Relevant information:

With automatic switching function (option), the other gyrocompass is automatically selected.

When calling at a port, contact SIMRAD service center.

### **TS-02 - Communication error between the system and the NO.1 gyrocompass control unit**

Procedure and treatment:

- 1 Check the working condition of the NO.1 gyrocompass.
- 2 If the NO.1 gyrocompass is abnormal, fix the abnormality by following the operator manual of the gyrocompass.

Relevant information:

If an alert or symptom cannot be fixed, contact SIMRAD service center.

### **TS-03 - Communication error between the system and the NO.2 gyrocompass control unit**

Procedure and treatment:

- 1 Check the working condition of the NO.2 gyrocompass.
- 2 If the NO.2 gyrocompass is abnormal, fix the abnormality by following the operator manual of the gyrocompass.

Relevant information:

If an alert or symptom cannot be fixed, contact SIMRAD service center.

### **TS-05 - Communication error of the NO.1 gyrocompass signal processing unit of Double**

Procedure and treatment:

- 1 Check the status of the service switch SW101 and the fuse XF101 in the system.

Relevant information:

If an alert or symptom cannot be fixed, contact SIMRAD service center.

**TS-06 - Communication error of the NO.2 gyrocompass signal processing unit of Double**

Procedure and treatment:

- 2 Check the status of the service switch SW102 and the fuse XF102 in the system.

Relevant information:

If an alert or symptom cannot be fixed, contact SIMRAD service center.

**TS-07 - Display communication error**

Procedure and treatment:

- 1 Check the fuse XF103 in the system.

Relevant information:

If an alert or symptom cannot be fixed, contact SIMRAD service center.

**TS-08 - Communication error of the Double control unit**

Procedure and treatment:

- 1 Turn OFF the service switches SW101 and SW102. Then turn ON all of the switches again.

Relevant information:

If an alert or symptom cannot be fixed, contact SIMRAD service center.

**TS-11 - Power supply interruption or power failure from the NO.1 gyrocompass control unit to Double**

Procedure and treatment:

- 1 Check the condition of the service switch SW101 and the fuse XF101.
- 2 Check the fuse of the NO.1 gyrocompass by following the operator manual.

Relevant information:

If an alert or symptom cannot be fixed, contact SIMRAD service center.

**TS-12 - Power supply interruption or power failure from the NO.2 gyrocompass control unit to Double**

Procedure and treatment:

- 1 Check the condition of the service switch SW102 and the fuse XF102.
- 2 Check the fuse of the NO.2 gyrocompass by following the operator manual of the gyrocompass.

Relevant information:

If an alert or symptom cannot be fixed, contact SIMRAD service center.

### **TS-14 - Power failure of the NO.1 gyrocompass communication system of Double**

Procedure and treatment:

- 1 Check the service switch SW101 and the fuse XF101 in the system.
- 2 Check the fuse of the NO.1 gyrocompass following the operator manual of the gyrocompass.

Relevant information:

If an alert or symptom is not fixed, contact SIMRAD service center.

### **TS-15 - Power failure of the NO.2 gyrocompass communication system of Double**

Procedure and treatment:

- 3 Check the service switch SW102 and the fuse XF102 in the system.
- 4 Check the fuse of the NO.2 gyrocompass following the operator manual of the gyrocompass.

Relevant information:

If an alert or symptom is not fixed, contact SIMRAD service center.

### **TS-16 - Power failure of the internal communication system of Double**

Procedure and treatment:

- 1 Check the fuse XF103 in the system.

Relevant information:

If an alert or symptom is not fixed, contact SIMRAD service center.

### **TS-17 - Power failure of the NO.1 gyrocompass analog system of Double**

Procedure and treatment:

- 1 Check the condition of the service switch SW101 and the fuse XF101 in the system.
- 2 Check the fuse of the NO.1 gyrocompass following the operator manual of the gyrocompass.

Relevant information:

If an alert or symptom is not fixed, contact SIMRAD service center.

### **TS-18 - Power failure of the NO.2 gyrocompass analog system of Double**

Procedure and treatment:

- 1 Check the condition of the service switch SW102 and the fuse XF102 in the system.
- 2 Check the fuse of the NO.2 gyrocompass following the operator manual of the gyrocompass.

Relevant information:

If an alert or symptom is not fixed, contact SIMRAD service center.

### **TS-19 - Switch failure of the heading sensor**

Procedure and treatment:

- 1 Check the condition of the service switches SW101 and SW102. Then check the fuses XF101 and XF102 in the system.

Relevant information:

If an alert or symptom is not fixed, contact SIMRAD service center.

### **TS-20 - CPU restart detection**

Procedure and treatment:

- 1 Check the heading information of the gyrocompass and the external heading sensor which is displayed in the system coincides with the heading information of each heading sensor.
- 2 Check that the heading information of the equipment connected with the system coincides with the heading information of the heading sensor selected by the system.

Relevant information:

The alert is cleared by restarting the system.

Perform it when the vessel is at anchor.

### **TS-21 - Gyrocompass integrity failed**

Procedure and treatment:

- 1 Check the working condition of the gyrocompasses.
- 2 Check the setting parameter of the gyrocompasses (latitude, vessel speed).

Relevant information:

If an alert or symptom is not fixed, contact SIMRAD service center.

### **TS-22 - Gyrocompass integrity doubtful 1**

Procedure and treatment:

- 1 Check the working condition of the unselected gyrocompass.
- 2 Check that the unselected gyrocompass has been started more than about 3 hours ago (Not under standby mode).

Relevant information:

If an alert or symptom is not fixed, contact SIMRAD service center.

### **TS-23 - Gyrocompass integrity doubtful 2**

Procedure and treatment:

- 1 Check the alarm condition of selected gyrocompass.
- 2 Check if the GPS or the LOG communication error is ON, recover the system.

- 3** After confirming the system recovery, push the **ACK/ENT** key to determine the heading of selected gyrocompass.

Relevant information:

If an alert or symptom is not fixed, contact SIMRAD service center.

### **TS-24 - Gyrocompass abnormality**

Procedure and treatment:

- 1** Refer to the troubleshooting method of Expanded System operator manual.

Relevant information:

If an alert or symptom is not fixed, contact SIMRAD service center.



