

Autopilot Pump Fitting Kits for ORB Steering Systems

Installation Guide

Tools required: Safety glasses, wrenches 15 mm ($\frac{9}{16}$ ") and 16 mm ($\frac{5}{8}$ "), liquid Teflon® sealant (SteadySteer™ kit only)

AUTOPILOT PUMP FITTING KIT For ORB Steering System (000-15942-001)

- 2 x hoses (black), 1500 PSI max, 750 mm (29.5"), $\frac{9}{16}$ " UNF > $\frac{9}{16}$ " UNF
- 1 x hose (clear), 65 PSI max, 750 mm (29.5"), $\frac{9}{16}$ " UNF > $\frac{9}{16}$ " UNF
- 2 x tee connectors ORB-5M > $\frac{9}{16}$ " UNF > $\frac{9}{16}$ " UNF
- 1 x 90° elbow connector ORB-5M > $\frac{9}{16}$ " UNF
- 1 x bottle of hydraulic steering fluid
- 1 x paper filter funnel

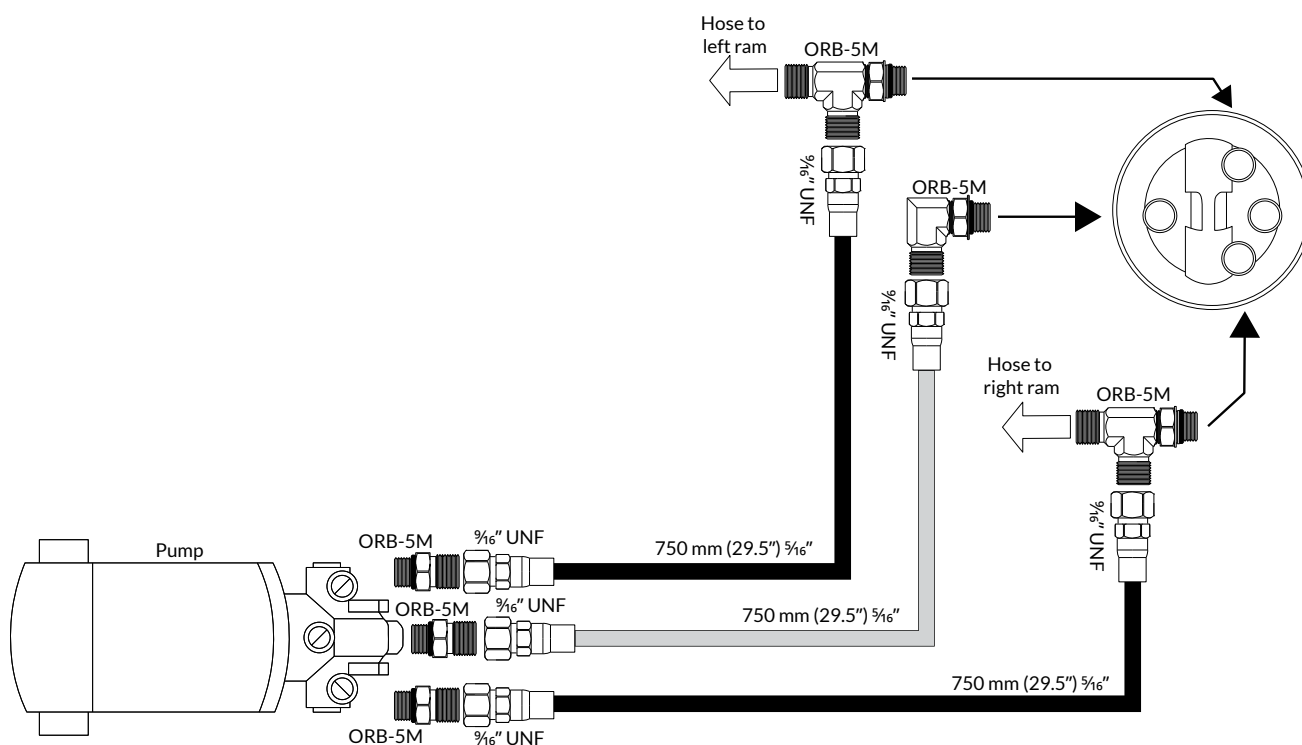

Install pump (pump kit sold separately)

1. Select an installation location for your pump within the combined length of the hoses from the pump and the back of the helm.
2. Ensure the pump and hoses are below the helm to eliminate trapped air. Mount the pump in your preferred orientation (horizontal or vertical).
3. Connect the ORB-5M > $\frac{9}{16}$ " UNF fittings to the pump and tighten.
 - **Note:** If mounting vertically, do not mount the pump above the motor.
 - **Note:** You can connect the tee connectors to the pump if space is limited behind the helm.

Connect hoses to pump

- **Warning:** Check the O-ring is inserted before you tighten any hose fitting.
 - **Warning:** Do not use Teflon® tape or liquid sealant on UNF or ORB hydraulic hose fittings.
 - **Warning:** Use the correct wrench to tighten hose fittings. Do not overtighten.
4. Connect the black high pressure hoses to the outer (main steering line) fittings on the pump.
 5. Connect the clear low pressure hose to the middle (balance line) fitting on the pump.

Connect hoses to connectors

6. Connect the black high pressure hoses to the center $\frac{1}{16}$ " UNF thread on the tee connectors.
7. Connect the clear low pressure hose to the $\frac{1}{16}$ " UNF thread on the elbow connector.

Disconnect hoses from helm

8. Turn off power and ensure the motor key switches are in the OFF position.
9. Remove and secure the hydraulic ram hoses connected to the helm.
10. Remove existing ORB fittings from the helm. These are not required.

Connect connectors to helm

11. Connect the ORB side of the tee connector to the helm main steering line ports.
12. Connect the ORB side of the elbow connector to the helm balance line port.

Reconnect hoses from hydraulic ram

13. Reconnect the hydraulic ram hoses to the side $\frac{1}{16}$ " UNF threads on the tee connector.

Refill hydraulic system

14. Refill the hydraulic system with hydraulic steering fluid, and bleed as per the instructions at the end of this document.

Autopilot pump fitting kit with SteadySteer™ (000-15949-001)

- 2 x hoses (black), 1500 PSI max, 360 mm (14.2"), $\frac{1}{16}$ " UNF > $\frac{1}{16}$ " UNF
- 1 x hose (black), 1500 PSI max, 810 mm (31.9"), $\frac{1}{16}$ " UNF > $\frac{1}{16}$ " UNF
- 1 x hose (clear), 65 PSI max, 810 mm (31.9"), $\frac{1}{16}$ " UNF > $\frac{1}{16}$ " UNF
- 2 x tee connectors, ORB-5M > $\frac{1}{16}$ " UNF > $\frac{1}{16}$ " UNF
- 1 x 90° elbow connector, ORB-5M > $\frac{1}{16}$ " UNF
- 1 x steadySteer™ hydraulic flow switch
- 2 x adaptors, $\frac{1}{4}$ " NPT > $\frac{1}{16}$ " UNF
- 1 x bottle hydraulic steering fluid
- 1 x paper filter funnel

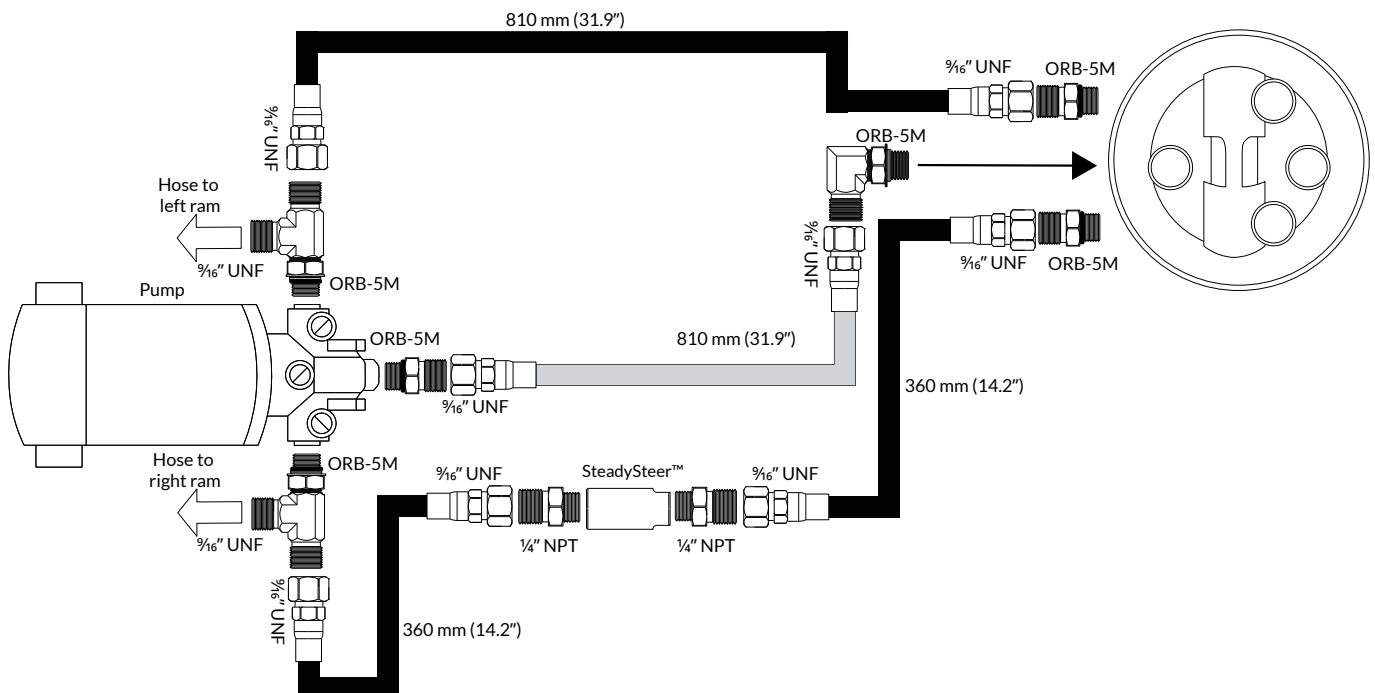

Install pump (pump kit sold separately)

1. Select an installation location for your pump within the combined length of the hoses from the pump and the back of the helm.
2. Ensure the pump and hoses are below the helm to eliminate trapped air. Mount the pump in your preferred orientation (horizontal or vertical).
 - **Note:** If mounting vertically, do not mount the pump above the motor.
3. Connect an ORB-5M > $\frac{1}{16}$ " UNF fitting to the pump (balance line) port and tighten.
 - **Note:** The 2 remaining ORB-5M > $\frac{1}{16}$ " UNF fittings are not used.
 - **Note:** You can connect the tee connectors to the helm if space is limited around the pump.

Connect connectors to pump

- **Warning:** Check the O-ring is inserted before you tighten any hose fitting.
- **Warning:** Do not use Teflon® tape or liquid sealant on UNF or ORB hydraulic hose fittings.
- **Warning:** Use the correct wrench to tighten the hose fittings. Do not overtighten.
- 4. Connect the ORB thread of the tee connectors to the outer (main steering line) fittings on the pump.

Connect hoses to connectors

5. Connect one 360 mm (14.2") black high pressure hose to the side 1/16" UNF thread on a tee connector.
6. Connect the 810 mm (31.9") black high pressure hose to the side 1/16" UNF thread on a tee connector.
7. Connect the 810 mm (31.9") clear low pressure hose to the 1/16" UNF thread on the middle connector.

Connect hoses to SteadySteer™

- **Note:** The SteadySteer™ flow switch must be fitted horizontally on either the starboard or port hydraulic line.
- 8. Coat the 1/4" NPT threads of the 2 adapters with liquid Teflon® sealant. Do not use Teflon® tape.
- 9. Connect the 1/4" NPT threads of the 2 adapters to each end of the SteadySteer™ flow switch.
- 10. Connect the two 360 mm (14.2") black high pressure hoses to the 1/16" UNF threads of the 2 adapters.

Disconnect hoses from helm

11. Turn off power and ensure the motor key switches are in the OFF position.
12. Remove and secure the hydraulic ram hoses connected to the helm.

Reconnect hoses from hydraulic ram

13. Reconnect the hydraulic ram hoses to the center 1/16" UNF threads on the tee connectors.

Connect hoses to helm

14. Connect the black high pressure hoses to the helm main steering line ports.
15. Connect the clear low pressure hose to the helm balance line port using the elbow connector.

Refill hydraulic system

16. Refill the hydraulic system with hydraulic steering fluid, and bleed as per the instructions at the end of this document.

SteadySteer™ key features

- Allows autopilot to keep you going straight between the turns
- Allows immediate manual control at any time
- Detects helm movement and temporarily overrides autopilot while turning
- Re-engages autopilot upon exiting the turn
- No key-press, no alarms, no fuss, simply turn the helm
- Usable in steering modes: Auto, NoDrift and Navigation

SteadySteer™ compatibility

- Fully compatible with:
 - NAC™ 2 and NAC™ 3 autopilot computers with minimum software version 1.1.05
 - NAC™ D autopilot computers with minimum software version 1.0.01.01
 - AP™ 44 and AP™ 48 autopilot controllers with minimum software version 2.2.57.3.163
 - Simrad® MFD with minimum software version 20.2
 - Lowrance® HDS® Live with minimum software version 22.1
- Compatible with older Simrad® MFDs when an AP™ 44 or AP™ 48 is used to configure the digital input port for the flow switch.
- Pumps 2,3,4, or 5 with part numbers ending in -002, and legacy RPU pumps.

Wiring and configuration

- For wiring details, refer to the documentation for your autopilot computer.
- Before the SteadySteer™ can be used, make sure the proper autopilot settings have been configured. Refer to the documentation for your autopilot computer.

System wiring example NAC™ 2

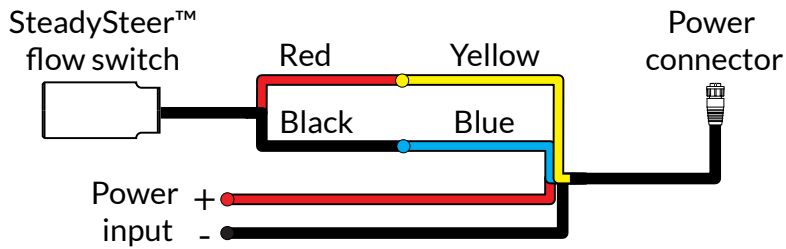

System wiring example NAC™ 3



Bleeding the steering system

1. Remove the motor leads from the NAC™ autopilot computer.
 2. With power supplied to the NAC™ autopilot computer, connect the red pump wire to +12 V input and black wire to negative input. The pump will run and start to drive the rudder/motor in one direction. When the rudder/motor reaches the end, stop. (Perform this step with someone watching the rudder/motor to inform you when to stop.)
 3. Reverse the wires. Connect the red pump wire to the negative terminal of the NAC™ autopilot computer and the black wire to the +12 V terminal. Again, with someone watching for the endstop.
 4. Repeat steps 2 & 3 several times until you no longer hear air in the pump and lines and the rudder/motor moves smoothly and evenly.
- **Note:** For how to bleed the steering system, see the Steering System installation manual.

Compliance statements

Declarations

The relevant declarations of conformity are available at:

www.simrad-yachting.com, www.lowrance.com and www.bandg.com.

United Kingdom

This product complies with UKCA under Electromagnetic Compatibility Regulations 2016.

Europe

This product complies with CE under EMC Directive 2014/30/EU.

United States of America

Note: The user is cautioned that any changes or modifications not expressly approved by the party responsible for compliance could void the user's authority to operate the equipment.

Australia and New Zealand

This product complies with the requirements of Level 2 devices of the Radiocommunications (Electromagnetic Compatibility) Standard 2017.

Copyright

Copyright © 2022 Navico Holding AS.

Trademarks

®Reg. U.S. Pat. & Tm. Off, and ™ common law marks. Visit www.navico.com/intellectual-property to review the global trademark rights and accreditations for Navico Holding AS and other entities.

Warranty

The warranty card is supplied as a separate document. In case of any queries, refer to the brand website of your unit or system.

