

K-int 4

Lysdioder:

NMEA: Indikerer når det motaes data.
 OK: Indikerer når NMEA-setning er gyldig.

NB!
 Velg Fluxgatekompass som styrekompass på Robertson autopilot

NB!
 Velg "Special Fluxgate" som kompass type i oppsettet for ComNav 1201 autopilot

Check-sum:

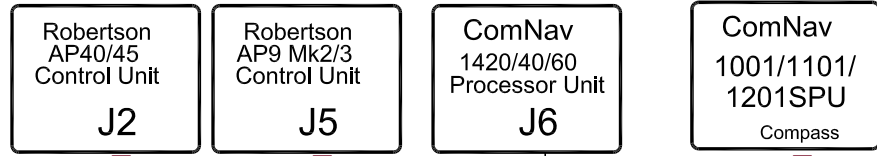
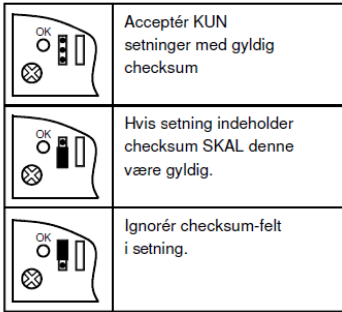

NB!
 Navman Rate gyro må også være tilkoblet.
 Vanlig kalibreringsprosedyre for autopiloten benyttes

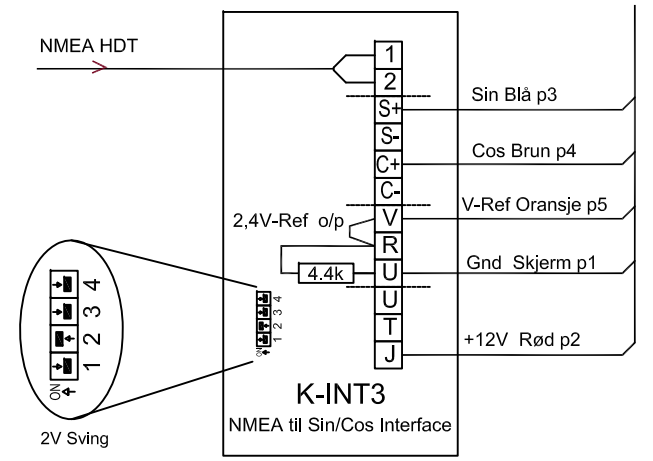
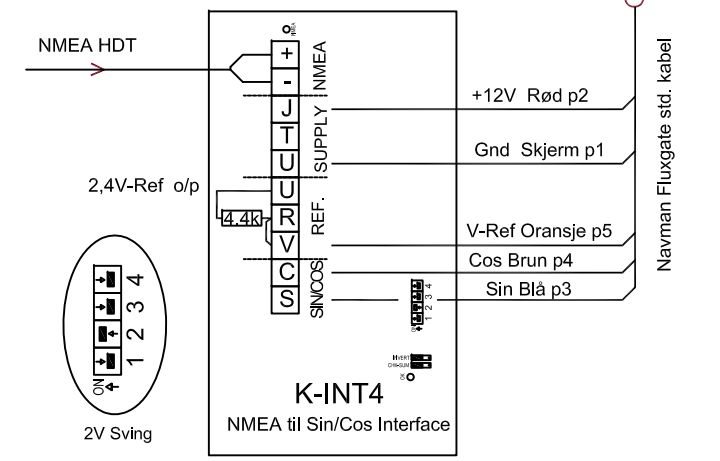
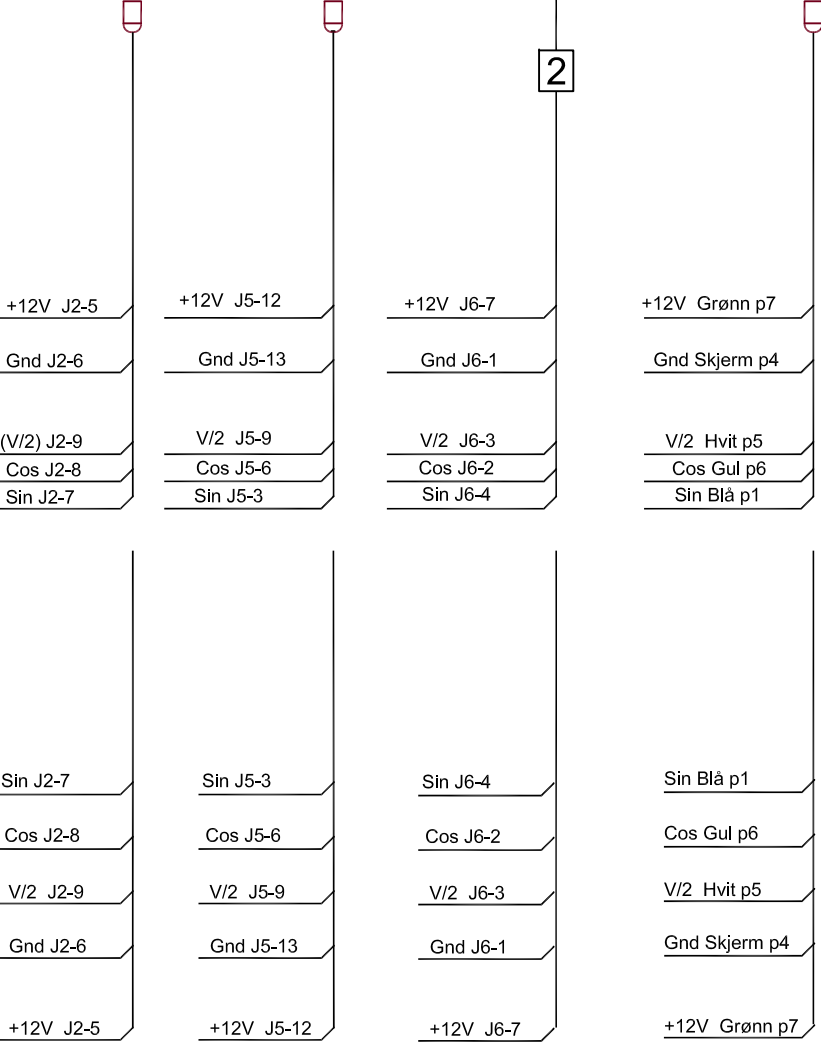
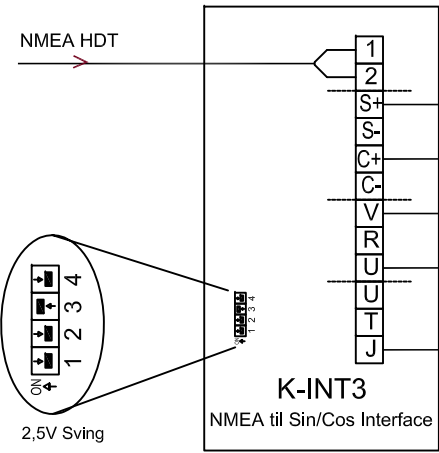
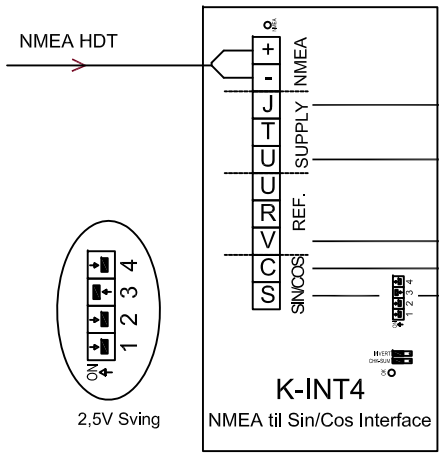
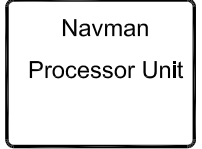

NB!
 Max strømtrekk ut fra autopilotene er 100mA

K-INT3/4 Interface ComNav, Navman og Robertson autopilot		ProNav as Postboks 421 4371 Egersund Tlf. 51 49 43 00 Fax. 51 49 21 00		 MARITIM ELEKTRONIKK	
Prosjekt	Ark 1av1	Dato 23/1-09	Tegnet av: Rune	Fil K-INT3_4-autopilot_m_navman	Rev. -